

***Log Max***

# **7000XT Top Saw**

## **User Manual**

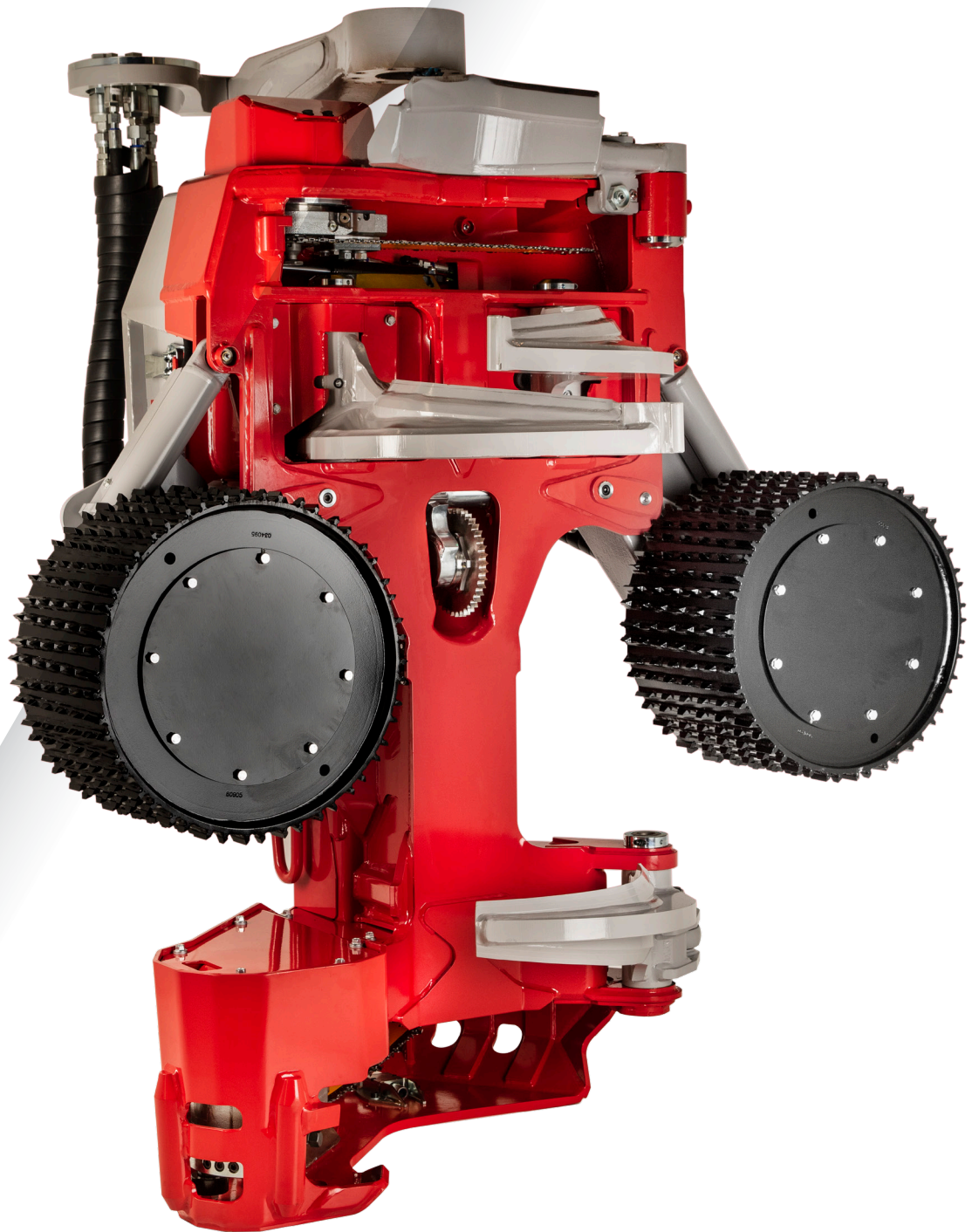

[www.logmax.com](http://www.logmax.com)

[en] 1.6

User Manual in Original





---

Stationsvägen 12 - 77013 Grangärde - Sweden Tel. +46 240 59 11 00 [info@logmax.com](mailto:info@logmax.com)



---

## Table of contents

<b>Foreword</b>	11
<b>About this manual</b>	11
Copyright	11
Comments and suggestions	11
Definitions	12
<b>Safety</b>	13
<b>General</b>	13
<b>Warnings and symbols</b>	13
<b>Safety stickers</b>	14
Head	14
Carrier	14
<b>Knowledge requirements</b>	15
<b>Protective equipment</b>	15
<b>Area of use</b>	15
<b>Risk zone</b>	15
<b>Chain shot</b>	16
<b>Crushing risk</b>	17
<b>Pressurised and hot liquids</b>	17
<b>Explosion risk</b>	18
<b>Modifications</b>	18
<b>Maintenance of the carrier</b>	18
<b>Information about warranties and complaints</b>	19
<b>Complaints</b>	19
<b>Installation instructions</b>	21
<b>Demands placed on the machine owner</b>	21
<b>Demands placed on the carrier</b>	21
<b>Function and design</b>	23
<b>Head overview</b>	23
<b>Rating plate</b>	24
<b>Frame and protective cover</b>	24
Frame	24
Wear plate at top saw	24
Upper wear plate	24
Lower wear plate	24
Protective cover	25
<b>Delimiting unit</b>	25

Upper delimiting knife	25
Active Friction Control™ (AFC)	26
Hydraulically controlled upper delimiting knife	26
Right and left delimiting knives	26
Lower delimiting knife	26
Fixed delimiting knife	26
<b>Feeding unit</b>	27
<b>Diameter measurement unit</b>	28
Two-point measurement	28
<b>Length measurement unit</b>	29
Length measurement with measuring wheel	29
<b>Felling link</b>	29
<b>Saw unit</b>	30
Saw 318	32
Saw 611	33
Chain lubrication, Super Greasy	34
<b>Extra equipment</b>	35
Colour marking equipment	35
Find End (Root search)	35
Stump treatment	36
<b>Handling</b>	37
<b>Transport of unattached head</b>	37
<b>Transport of head mounted on the carrier</b>	38
<b>Storage</b>	38
Prior to storage	38
During storage	39
After storage	39
<b>Scrapping and recycling</b>	40
<b>Handling</b>	41
<b>Starting up the head</b>	41
<b>Felling work</b>	42
Planning	43
Felling	43
Double cutting	44
Processing and sorting	44
Thick branches	45
Forks	45
<b>Parking on completion of the work</b>	46

<b>Unforeseen operational stoppages</b>	46
<b>Inspections and maintenance</b>	49
<b>Parking the head prior to inspections and maintenance</b>	51
Parking in the tilted up position	51
Parking in the tilted down position	52
<b>Rough cleaning</b>	52
<b>Inspecting the head</b>	52
Make sure that the head does not have any cracks	53
Inspecting stop buffers	53
Inspecting electrical wiring	53
<b>Inspecting wear plates</b>	54
Wear plate at top saw	54
Upper wear plate	54
Lower wear plate	54
<b>Inspecting and adjusting the protective cover and over-centre latches</b>	54
<b>Shafts for felling link, feed roller arms and delimiting knives</b>	55
Inspecting Log Max's standard shafts	55
Check of Expander	55
Torqueing the Expander	55
New Expander	56
Inspecting axial play	56
<b>Delimiting unit</b>	57
Delimiting knives' edges	57
Upper delimiting knife	57
Right and left delimiting knives	58
Lower delimiting knife	58
Fixed delimiting knife	58
Upper delimiting knife's spring and its preload	59
Replacement of the upper delimiting knife's spring	60
Basic setting and adjustment of upper delimiting knife sensor	60
Active Friction Control™ (AFC)	60
Checking and adjusting the upper delimiting knife's screw and nut in the groove	61
<b>Feeding unit</b>	61
Inspecting feed rollers	62
Tightening feed roller nuts	62

<b>Replacement of feed rollers</b>	62
Removing feed rollers	62
Installing feed rollers	62
Checking the tightening of screws for feed roller motors	63
<b>Diameter measurement unit</b>	63
<b>Length measurement unit</b>	64
Inspecting the length measurement unit	64
Replacing measuring wheel tracks	65
Lubricate the measuring wheel bearings	66
<b>Saw unit</b>	66
Inspecting chain shot guard	67
Fill with saw chain oil	67
Checking saw chain lubrication	68
Inspecting saw chain	68
Inspecting saw bar	68
Inspection of saw chain sprocket and saw chain catcher	69
Replace saw chain sprocket and saw chain catcher	70
Checking the stop screw	71
Replacing the stop screw	71
Saw 318	71
Tension saw chain	71
Replace saw chain	71
Replace saw bar	72
Cleaning behind the bar holder	72
Saw 611	73
Tension saw chain	73
Check the saw chain tension.	73
Replace saw chain	74
Replace saw bar	75
<b>Hydraulic system</b>	76
Replacing the hydraulic hose	77
Hydraulic hose with ORFS couplings	77
Hydraulic hose with BSP couplings	78
Hydraulic hose with banjo coupling	79
Hydraulic hose with JIC coupling	80
Hydraulic hose with WEO coupling	81
Inspection and replacement of accumulators	81
<b>Pressure check</b>	83



Inspection and adjustment of the pressure setting	83
Pressure settings	84
Special Instructions	85
Setting the main pressure	86
Checking servo pressure	86
Checking the function connected to “PL”	86
Setting the bar feed pressure	86
Adjusting the feed roller arm pressure	86
Checking measuring wheel pressure	86
Checking chain tensioning pressure for the top saw	86
Checking return pressure, top saw motor	86
<b>Extra equipment</b>	86
Colour marking equipment	87
Topping up with marking dye	87
Cleaning non-return valve in tank filler cap	87
Inspecting the colour marking pump	87
Cleaning the colour marking system	88
In the event of long breaks (several weeks)	88
Find End	88
<b>Repair welding</b>	89
<b>Maintenance schedule</b>	91
Lubrication schedule, 8 h	91
Maintenance schedule, 8 h	92
Maintenance schedule, 50 h	93
Maintenance schedule, 250 h	94
Maintenance schedule, 1,000 h	95
<b>Service information</b>	97
<b>Troubleshooting</b>	99
<b>Technical data</b>	101
<b>Dimensions and weight</b>	101
Dimensions and basic weight.	101
Weight of extra equipment	101
<b>Noise level</b>	101
<b>Temperature</b>	101
<b>Hydraulics</b>	102
Hydraulic oil requirements	102
General recommendations	102
Minimum hydraulic system requirements	102

---

<b>Saw chain speed</b>	102
<b>Lubricant</b>	103
Requirements regarding saw chain oil	103
Lubricating grease	103
<b>General tightening torques</b>	104
<b>General tightening torques with Nord-Lock washers</b>	105
<b>General tightening torque for Expander</b>	105

# Foreword

## About this manual

These instructions are for the Log Max 7000XT.

The manual provides information about how the harvester head (subsequently referred to simply as the “head”) works, is maintained and is used safely. Before starting to use the head, carefully study the manual.

The manual principally covers the basic mechanical and hydraulic design, function, operation and maintenance of the head. The demands placed on and the functionality of the head’s electrical control system are only covered in general terms.

### Note!

Your head is not necessarily fitted with all the equipment described in this manual.

For complete information about the control system installed in your head, refer to the manual for the control system in question.

Always store the manual in the carrier’s cab or in close proximity to the location where the work is being carried out, as the need for essential information regarding use, safety and maintenance may arise at any time.

### Note!

If the manual is lost, a new one should be procured immediately. The manual can be ordered from your dealer.

All information, including text, illustrations and specifications, is based on the product information that was available when the manual was created.

The illustrations contained in this manual are occasionally representative examples, and are not therefore always exact depictions of the head and its components.

## Copyright

Only Log Max AB owns full copyright to this manual and its contents. It is prohibited to copy or distribute all or part of this manual in any way without the written consent of Log Max AB.

## Comments and suggestions

Please leave your comments and suggestions regarding the manual. Write down anything that should be changed and send it to [manual@logmax.com](mailto:manual@logmax.com).

### Note!

To avoid any misunderstanding, it is safest to submit comments and suggestions in English or Swedish.

### Definitions

Below are a summary and explanation of specific expressions that are used in this manual and that are not explained elsewhere.

Expressions	Explanation
Head	The machine to which this manual applies. Can also be referred to as a grapple harvester, harvester unit, harvester head.
Carrier	The machine on which the head is mounted. Can also be referred to as a carrier, tractor, transport vehicle.
Operating hours (h)	Engine hours calculated by the carrier's hour counter. Abbreviated to "h" in certain contexts.
h	See "Operating Hours".
Hot work	Service work where a lot of heat is generated, such as repair welding.
Counter-chamfer	The chamfer of the delimiting knife's edge that is closest to the stem.
DBH	Diameter at breast height. The tree's stem diameter 130 cm from ground level.

# Safety

## General

Incorrect use of the head can result in serious injuries to the operator as well as serious damage to the head and the surroundings. It is therefore important to read, understand and follow the instructions in this manual before starting to use the head.

If the provisions in this manual deviate from local laws and regulations, you are obligated to comply with local laws and regulations.

## Warnings and symbols

The following warnings and symbols are used in this manual to alert you to risks that could result in personal injury or death.



### **Danger!**

Danger indicates that an accident could occur if the regulation is not followed. Such an accident could result in permanent loss of capacity to work or to death.



### **Warning!**

Warning indicates that an accident could occur if the regulation is not followed. Such an accident could result in serious personal injury.



### **Caution!**

Caution indicates that an accident could occur if the regulation is not followed. Such an accident could result in personal injury.

The following warning is used in this manual to alert you to risks that could result in material damage.

### **Important!**

Important indicates that an accident could occur if the regulation is not followed. Such an accident could result in material damage.

Additional information is highlighted as shown below.

## Note!

Clarifies information that is important for understanding or executing operations.

## Safety stickers

Safety stickers must be clearly visible, legible and complete. If a sticker is damaged or missing, it must be replaced. Safety stickers can be ordered from your dealer.

## Head

The head is equipped with safety stickers that warn about circumstances that could result in serious injury or death. The safety stickers have a yellow background.

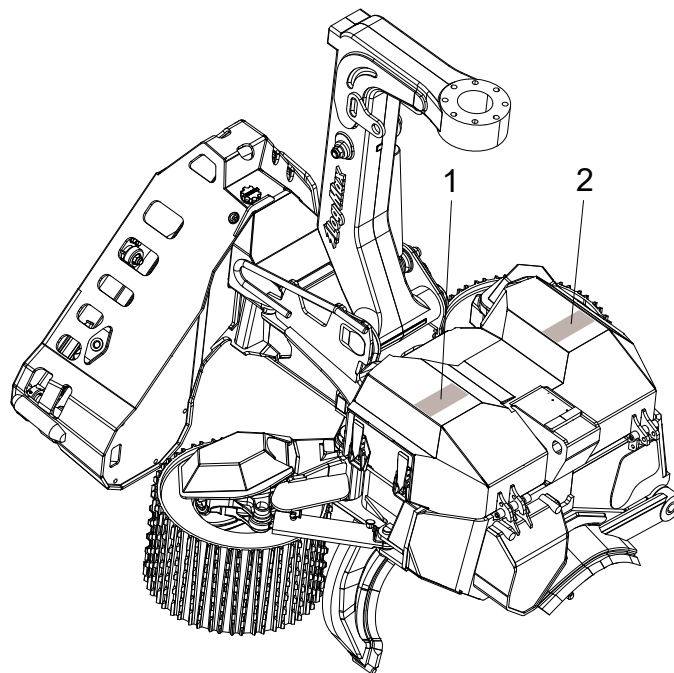

The following safety stickers are affixed to the head:

1. Warning about chain shots
2. Warning of crushing risk

## Carrier

The carrier's crane must be supplied with safety stickers indicated a risk zone of at least 90 metres.

## **Knowledge requirements**

All work using the head may only be carried out by individuals possessing the requisite knowledge about the work that is to be carried out. This applies in particular, although not solely, to:

- handling and transport.
- installation on the carrier.
- normal use.
- maintenance.
- service.

Requisite knowledge refers to the knowledge that is required to carry out the work correctly and safely.

## **Protective equipment**

Use the protective equipment that is necessary for the work that is to be carried out, for example: helmet, safety shoes, gloves, ear defenders, safety goggles.

## **Area of use**

The head is intended solely for logging work, where the head fells and processes trees. Any other use is prohibited. Examples of prohibited use include:

- towing machinery.
- handling loads other than trees.

## **Risk zone**

When the head is used for felling and processing trees, a safety distance of at least 90 metres must be observed by anyone who is outside of the carrier's cab.

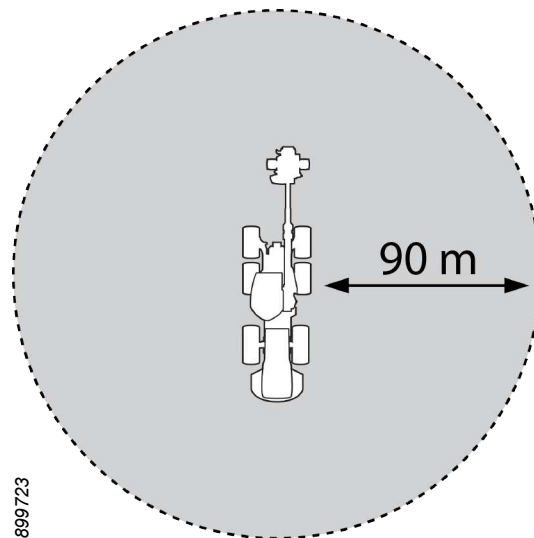

899723

The operator is obliged to stop work immediately if someone is within the risk zone.

## Chain shot

When a saw chain breaks, parts of the saw chain can be thrown out at high speeds. If saw chain breaks with a whiplash, the speed of these parts may be several times higher than the speed of the saw chain.

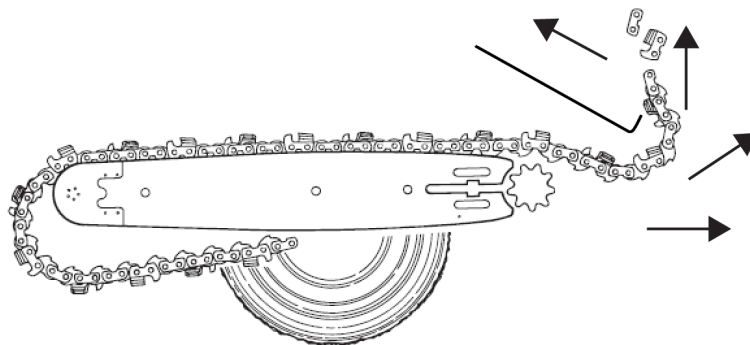

899734



### **Danger!**

Chain shots are associated with danger to life! The energy in the event of chain shot can be equivalent to that of a bullet from a rifle.

It is therefore essential to follow the instructions regarding the use of the head and maintenance of the saw unit.





### Danger!

In the event of chain shots, parts of the saw chain can travel outside of the head's risk zone.

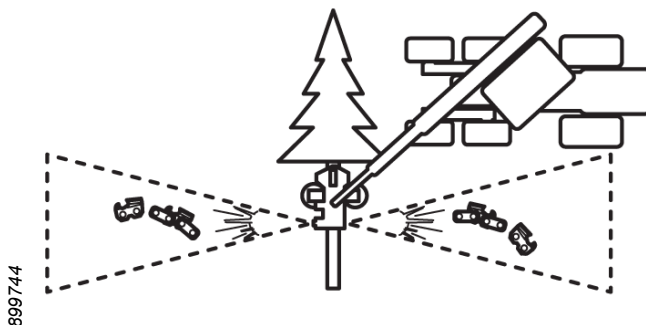

899744

When activating the saw unit, the head must be positioned so that there is no risk of chain shots hitting:

- the carrier's cab.
- people outside the risk zone.
- other machines.
- other property.

The head is equipped with a chain shot guard. The guard is integrated into the head's frame. Under no circumstances may the guard be modified. Do not use the head if the guard has been damaged or its function has otherwise been impaired.

## Crushing risk

A crushing risk exists by the head's moving parts. Follow the instructions in this manual in connection with inspection and maintenance work.

## Pressurised and hot liquids

The head works with liquids under high pressure that can reach high temperatures. A risk of cuts and burns exists in the event of leaks. Follow the instructions in this manual in connection with inspection and maintenance work.

### **Explosion risk**

The head is equipped with closed areas that may contain flammable liquids. An explosion risk exists in the event of hot work in the vicinity of these areas.

The head's hydraulic system is equipped with accumulators. These are filled with gas under high pressure. If an accumulator fails, the gas can be released explosively.

Follow the instructions in this manual in connection with inspection and maintenance work.

### **Modifications**

Any modifications of the head must be approved by Log Max AB. Retrofitting of additional equipment must be carried out by technicians possessing the requisite knowledge about the head and the additional equipment.

### **Maintenance of the carrier**

Follow all instructions regarding the maintenance and use of the carrier contained in its manual.

Keep the carrier's cab tidy and the windows clean.

The carrier's doors and windows must be kept closed when the head is in operation.

## Information about warranties and complaints

The head may be covered by various warranties. The warranty conditions that apply must have been procured at the time of the sale of the head, and can be seen from the sales contract.

In order for a warranty to be valid:

- operation and maintenance of the head must take place in accordance with this manual.
- installation of the head must be performed correctly according to the installation instructions supplied by Log Max AB.
- the warranty card must be correctly filled in and sent to Log Max AB within the time period specified on the warranty card.

### **Note!**

The installation of equipment on the head that has not been approved by Log Max AB may invalidate all or part of head's warranty.

Log Max AB accepts no responsibility for consequential damage resulting from unauthorised equipment.

## Complaints

If a component on the head, which is not a consumable part, breaks down within the warranty period, a claim should be submitted. The claim regarding the component must be submitted to the dealer for the head or the dealer for the component.

Claims are lodged by submitting a correctly filled out claim report to the dealer.



## Installation instructions

Installation instructions will accompany the head on delivery. Contact Log Max AB if the installation instructions are missing.

Installation, start-up checks and delivery service on heads may only be carried out by technicians possessing the requisite knowledge.

### Demands placed on the machine owner

The machine owner is obliged to ensure compliance with applicable safety regulations for the complete machine in accordance with EU Machinery Directive 2006/42/EC, 2014/30/EU and the current edition of ISO 11850.

### Demands placed on the carrier

In order for a head to be installed on a carrier, the carrier must satisfy the requirements in the current version of ISO 11850.

ISO 11850 stipulates demands including, but not limited to:

- the operator's seat must be protected against penetrating objects, including chain shots (OPS).
- the operator's seat is protected against falling objects (FOPS).
- the operator's seat is protected against rolling/tipping the machine (ROPS).
- the carrier is equipped with safety switches and emergency stops in appropriate locations.
- the combination of the carrier and the head is stable, see the table below.

Recommended weight		
 907119	 907125	 907122
<b>Head model</b>	<b>Harvester</b>	<b>Excavator</b>
Log Max 7000XT	-	25–35 tonnes

#### Note!

The table is only a recommendation. The size of the carrier that is required depends in part on carrier's design and crane length.



## Function and design

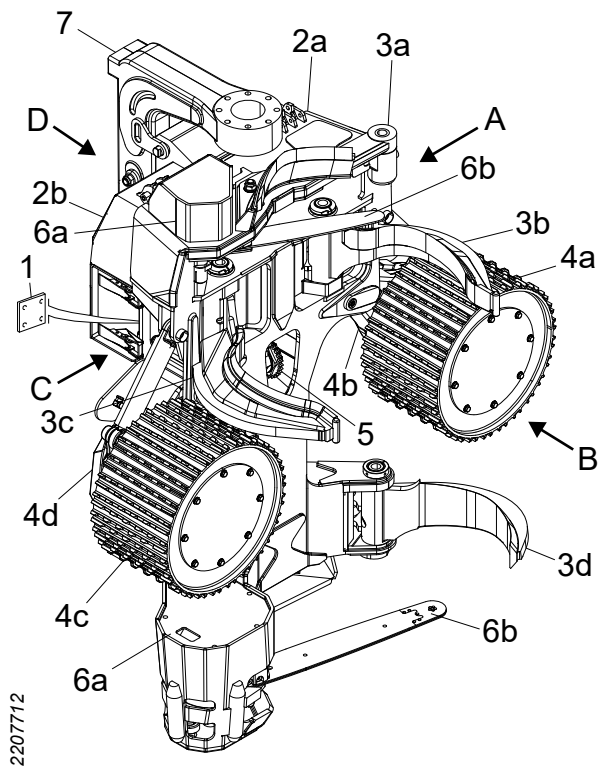

### Head overview

Below is an overview of the head's orientation and main components.

A	Left
B	Front
C	Right
D	Rear
1	Rating plate
2	Frame with protective cover
a	Frame
b	Protective cover
3	Delimiting unit
a	Upper delimiting knife
b	Left delimiting knife
c	Right delimiting knife
d	Lower delimiting knife
4	Feeding unit
a	Left feed roller
b	Left feed roller arm
c	Right feed roller
d	Right feed roller arm
5	Length measurement unit
6	Saw unit
a	Saw motor
b	Saw bar and saw chain
7	Felling link

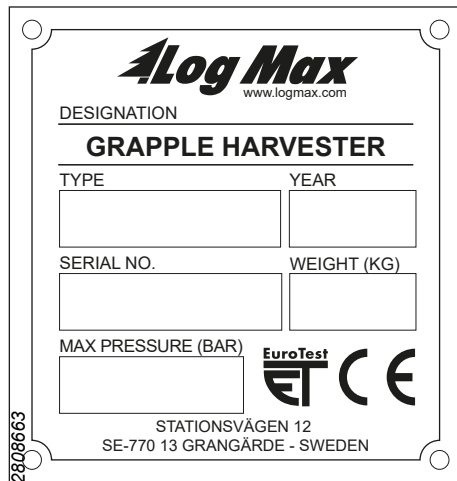

The rating plate is a rectangular metal plate with a decorative border. It features the Log Max logo at the top, followed by the company name and website. Below this, the designation 'GRAPPLE HARVESTER' is printed. The plate contains several fields for technical specifications: TYPE, YEAR, SERIAL NO., WEIGHT (KG), and MAX PRESSURE (BAR). It also includes the EuroTest ET and CE markings, and the manufacturer's address: STATIONSVÄGEN 12, SE-770 13 GRANGÄRDE - SWEDEN. A vertical number '2808663' is printed on the left side.

<b>Log Max</b> www.logmax.com	
<b>DESIGNATION</b> <b>GRAPPLE HARVESTER</b>	
TYPE	YEAR
SERIAL NO.	WEIGHT (KG)
MAX PRESSURE (BAR)	
EuroTest ET CE	
STATIONSVÄGEN 12 SE-770 13 GRANGÄRDE - SWEDEN	

### Rating plate

The head's rating plate is located under the protective cover on the right side of the head.

DESIGNATION =	Machine type
TYPE =	Head model
YEAR =	Year of manufacture
SERIAL NO. =	Serial number
WEIGHT (KG) =	Basic weight
MAX PRESSURE (BAR) =	Maximum hydraulic pressure

The CE marking is affixed to heads that comply with the EU Machinery Directive 2006/42/EC.

Any ET marking means that an independent third party has verified that the head complies with the EU Machinery Directive 2006/42/EC.

### Frame and protective cover

#### Frame

The frame has mounts for the head's other units and an integrated tank for saw chain oil.

#### Wear plate at top saw

The wear plate at the top saw (3) is welded above the top saw. The wear plate protects the frame against wear damage.

#### Upper wear plate

The upper wear plate (1) is welded to the upper part of the frame. The wear plate protects the frame against wear damage.

#### Lower wear plate

The lower wear plate (2) is welded to the lower part of the frame. The wear plate protects the frame against wear damage. The lower wear plate also has an integrated fixed delimiting knife.

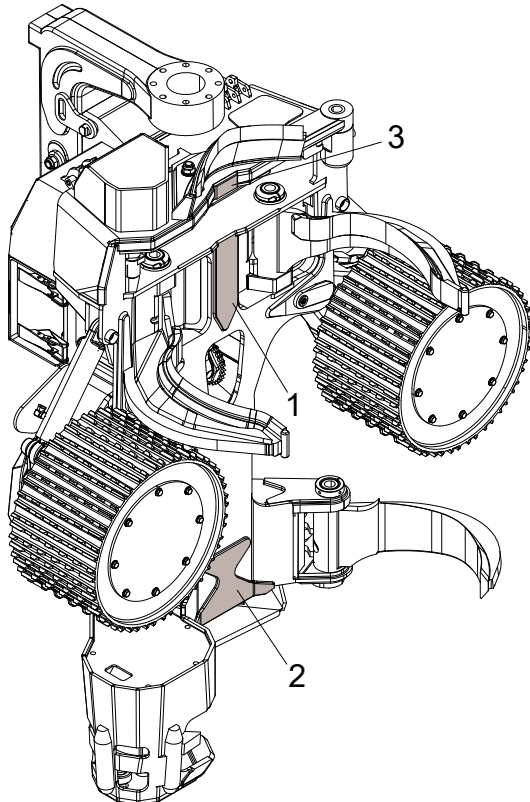



### Protective cover

The protective cover on the upper part of the frame protects important components in the head's control electronics and valve assembly. The protective cover is attached to the frame with hinges, over-centre latches and gas dampers. The over-centre latches enable quick and easy opening and closing of the protective cover. The gas damper helps to open and close the protective hood. The protective cover has adjustable stop screws to ensure that the protective cover is tight against the frame.

### Delimiting unit

The task of the delimiting unit is to cut the branches off the stem and hold the stem as it is fed through the head.

The delimiting unit is equipped with one fixed and four movable delimiting knives.

1. Upper delimiting knife
2. Left delimiting knife
3. Right delimiting knife
4. Lower delimiting knife
5. Fixed delimiting knife
6. Right protective plate
7. Left protective plate

- A Open  
B Close

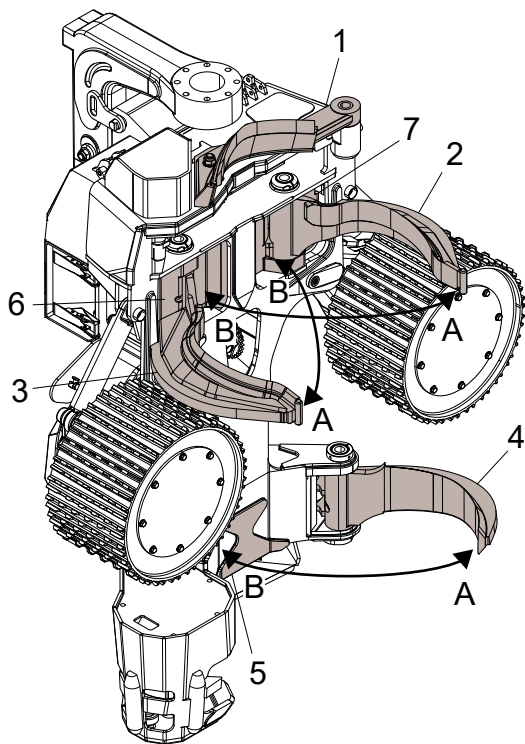

2208357

### Upper delimiting knife

The upper delimiting knife is spring-loaded so that it remains in contact with the stem. A sensor detects the position of the upper delimiting knife. In this way, the head's control system is able to measure the distance of the stem from the frame, i.e. the "stem position".

By opening and closing the other movable delimiting knives using the signal from the sensor, the head's control system can regulate the stem position.

The upper delimiting knife is of a fully welded design with interchangeable knife blades.

### **Active Friction Control™ (AFC)**

When the head is equipped with AFC, the desired stem position is set directly in the head's control system.

### **Hydraulically controlled upper delimiting knife**

When the unit is equipped with a hydraulically controlled upper delimiting knife, the head's control system can, if necessary, retract the upper delimiting knife against its stop lug.

### **Right and left delimiting knives**

The right and left delimiting knives are controlled by separate hydraulic cylinders, which in turn are controlled by a shared valve. The delimiting knives can close, open or stop in any position.

The right and left delimiting knife has an angled extension at the end of the delimiting knife, which makes it easier to pick up stems from a log pile. The rounded tip prevents the wood from being damaged when the stems are picked from the log pile. The extension also acts as a mechanical stop against the head frame.

### **Lower delimiting knife**

The lower delimiting knife is controlled by a hydraulic cylinder, which in turn is controlled by a valve. The delimiting knife can close, open or stop in any position.

The lower delimiting knife closes against a mechanical stop that is integrated into the frame.

### **Fixed delimiting knife**

The fixed delimiting knife is integrated into the frame's lower wear plate and enables some delimiting when feeding backwards.

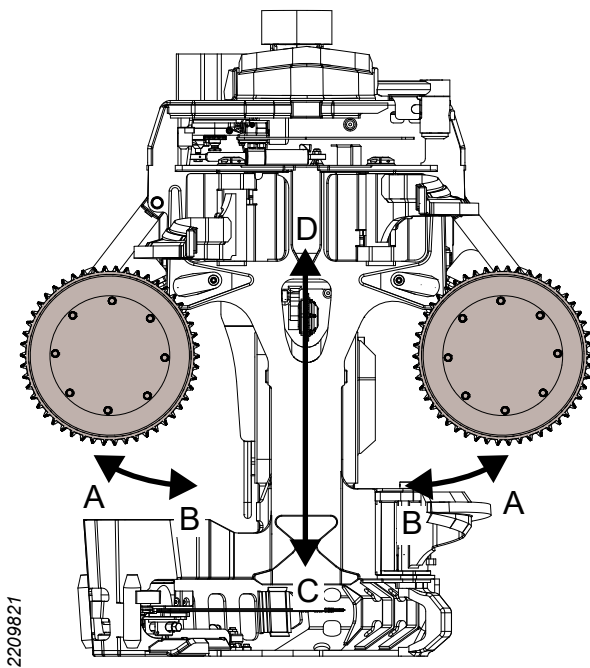

## Feeding unit

The feeding unit's task is to feed the stem through the head. The feeding unit is equipped with two feed rollers mounted on separate hydraulic motors, which are also known as feed roller motors. The feed roller motors are mounted on the right and left feed roller arms.

- A Open
- B Close
- C The stem's direction of travel when being fed forwards
- D The stem's direction of travel when being fed backwards

The feed roller motors are controlled by a shared valve. The feed roller motors can be controlled so that the feed rollers feed the stem forwards, backwards or stop in any position.

The feed roller arms are controlled by separate hydraulic cylinders, which in turn are controlled by a shared valve. The feed roller arms can close or open.

The hydraulic circuit for closing the feed roller arms is equipped with an accumulator. The task of the accumulator is to dampen pressure surges and guarantee the feed rollers' contact against the stem.

The feeding unit is designed so that the force of the feed rollers against the stem varies with the stem diameter, despite there being constant pressure in the hydraulic cylinders.

The movement of the feed roller arms is limited mechanically by the cylinders when the feed roller arms open, and against frame when the feed roller arms close. The frame is equipped with stop buffers to reduce the load on the feed roller arms and the frame.

Log Max AB provides three variants of feed rollers – V-steel Hard Grip, V-steel Soft Grip and Eucalyptus. All the variants are turned for good diameter measurement and the V-steel feed rollers are self-cleaning.

V-steel Soft Grip feed rollers are gentler with the logs than V-steel Hard Grip feed rollers. V-steel Hard Grip feed rollers allow greater penetration and consequently better grip. Eucalyptus feed rollers are designed to remove the bark from logs as they are fed through the head.

### Diameter measurement unit

The head can be equipped with sensors to measure the diameter of the stem that is being fed through the head.

The head's control system calculates the stem diameter using the signals from the sensors.

With the aid of length and diameter measurement, the head's control system can help the operator to divide up the tree into the timber dimensions that provide the best financial return.

### Two-point measurement

Using two-point measurement, diameter measurement is performed mechanically via the feed rollers and the feed roller arms. The sensors for the diameter measurement are mounted on the feed roller arms and detect movement of the feed roller arms.

1. Sensors

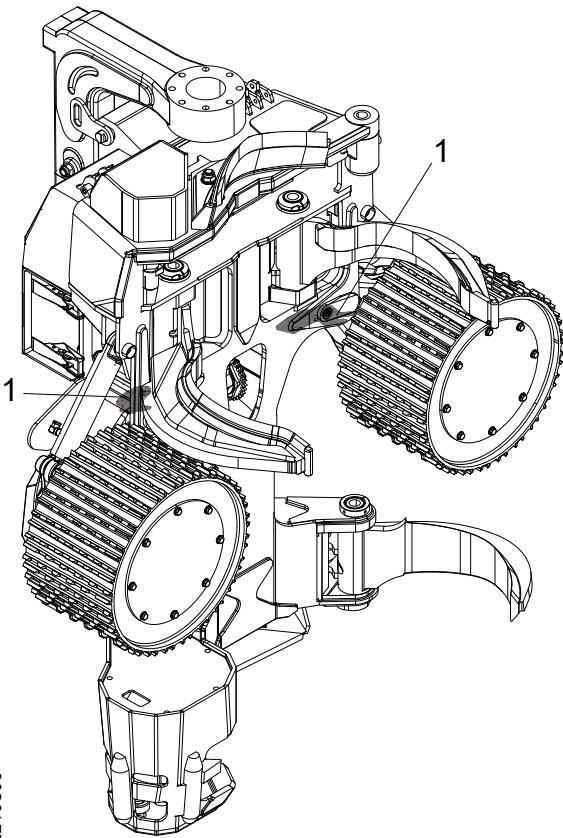

## Length measurement unit

The task of the length measurement unit is to measure the length of the stem that is being fed through the head.

### Length measurement with measuring wheel

Length measurement is performed mechanically with a measuring wheel that follows the stem. A sensor detects the rotation of the measuring wheel. The head's control system calculates the stem length using the signal from the sensor.

The measurement wheel is mounted on a measurement wheel arm that is controlled by a hydraulic cylinder. The hydraulic cylinder is controlled by an electrically controlled valve.

The measurement wheel can be applied against the log or be drawn into the frame.

The hydraulic circuit for applying the measuring wheel is equipped with an accumulator. The task of the accumulator is to dampen pressure surges and guarantee the measuring wheel's contact against the stem.

1. Measuring wheel arm
2. Measuring wheel
3. Hydraulic cylinder
4. Accumulator

The measuring wheel is made up of a number of different measuring wheel tracks. There are a range of measuring wheel track variants for different conditions. Contact your dealer for more information.

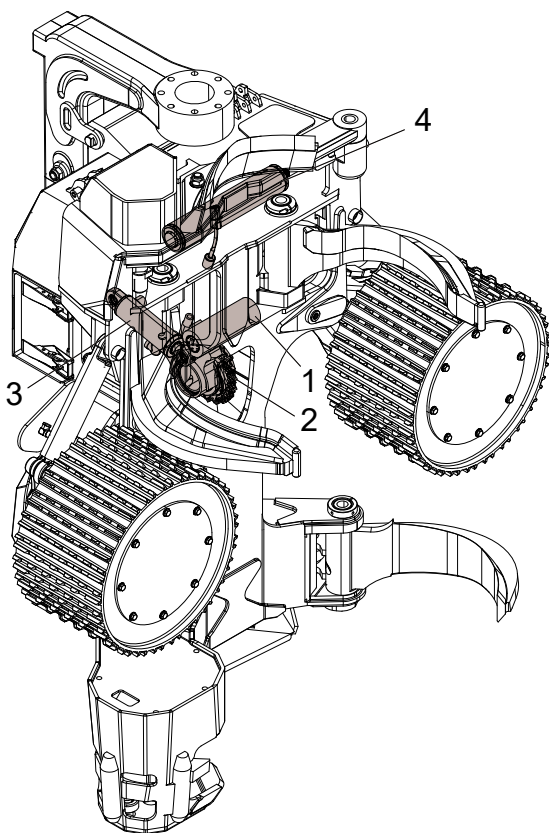

2211516

## Felling link

The task of the felling link is to tilt the head.

The felling link is controlled by a hydraulic cylinder, which in turn is controlled by a valve.

The movement of the felling link is limited mechanically against the head's frame and protective cover. The frame and the protective cover are fitted with stop buffers to reduce the load on the felling link, the frame and the protective cover.

Using the felling link, the head can tilt down, tilt up or turn freely, "floating mode".

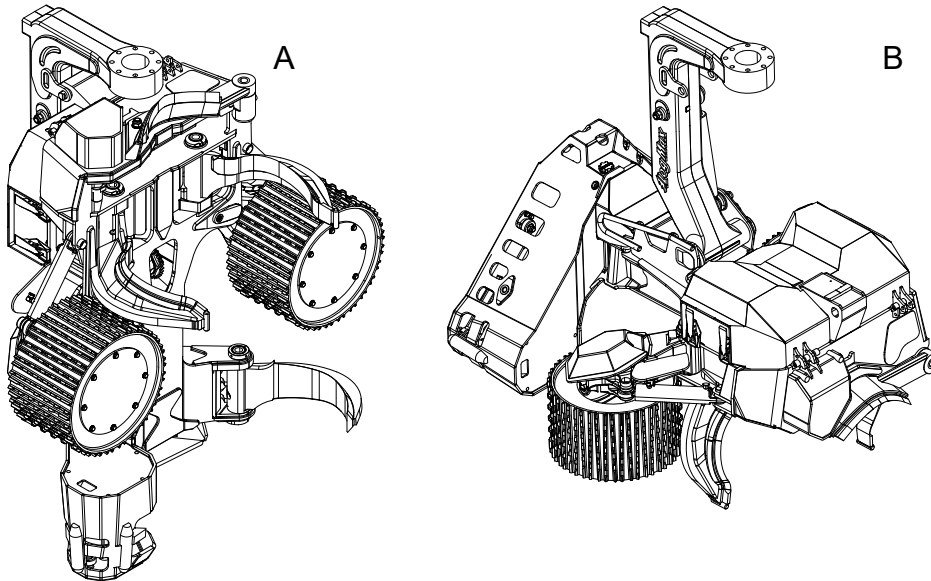

- A Tilted up
- B Tilted down

### Saw unit

The task of the saw unit is to cut off the stem so that the tree can be felled and cut up into the desired lengths.

The head is equipped with two saw head, one main saw and one top saw.

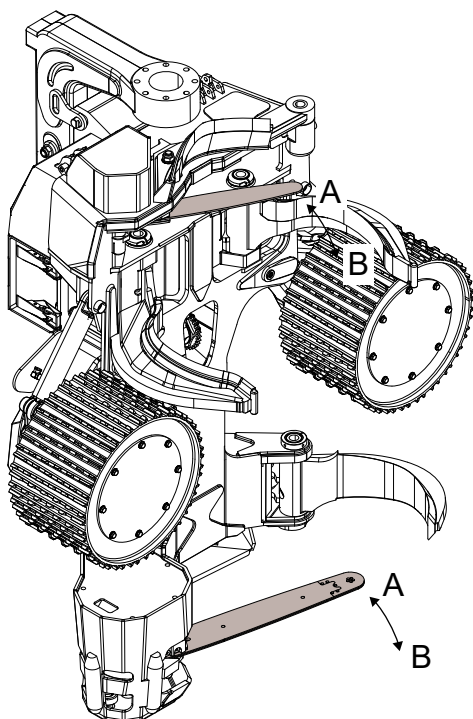

2212325

The saw unit is equipped with a saw chain mounted on a saw bar.

The saw bar can be withdrawn into the frame or run out towards the stem. When the saw bar is in the frame, it is said to be “home”. Otherwise, the saw bar is said to be “out”.

The saw bar’s direction of movement in event of:

- A Home movement
- B Outward movement

The saw bar is mounted on a bar mount, which in turn is mounted on a bearing unit. The bearing unit allows the bar to be moved out and home. The saw bar’s movement is controlled by a hydraulic cylinder, the “bar feed cylinder”. The movement of the saw bar is limited mechanically in each end position.

The saw chain is operated by a hydraulic motor, the “saw motor”, via a saw chain sprocket. The saw unit is equipped with a saw chain catcher that will prevent the saw chain from flying off in the event it becomes detached from the saw bar.

The main saw has two sensors that detect the position of the saw bar. One sensor detects whether the saw bar is in the home position, the “home position sensor”. The other sensor detects the saw bar’s movement, the “cutting control sensor”.

The head’s control system can use the signal from the home position sensor to prevent the activation of feeding forwards when the saw bar is out.

The head’s control system can use the signal from the cutting control sensor to adjust the outward movement of the saw bar in relation to the stem diameter.

The head is equipped with a chain shot guard, which is tasked with preventing chain shots from occurring in the event the saw chain breaks. The chain shot guard is integrated in the head’s frame.

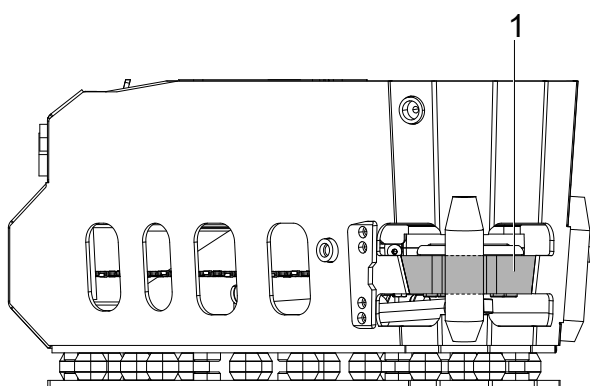

900417

1. Chain shot guard

### Saw 318

The saw motor's speed is controlled by a valve. The saw motor can only drive the saw chain in one direction. The saw motor speed is adjusted in the head's control system.

The bar feed cylinder is controlled by a valve.

The saw bar's outward movement is limited mechanically by the frame. The saw bar's homeward movement is limited mechanically by a stop screw. The stop screw is mounted in the frame and is also used to adjust the saw bar's home position. The stop screw is equipped with a damping element to reduce the load on the saw unit.

Saw 318 has an automatic saw chain tensioner that tensions the saw chain when the head is supplied with hydraulic pressure.

The main components in the saw chain tensioner are a bar holder, two tensioning pistons, a pressure reducing valve and an auto-release valve. The saw bar is mounted on the bar holder, which in turn is movably mounted in the bar mount.

The tensioning pistons are supplied with hydraulic pressure from the pressure reducing valve and press against the bar holder so that the saw chain is tensioned.

The auto-release valve makes it possible, by hand, to press the bar holder to its innermost position when the pressure supply to the head has ceased. This function is used, for example, when replacing the saw chain.

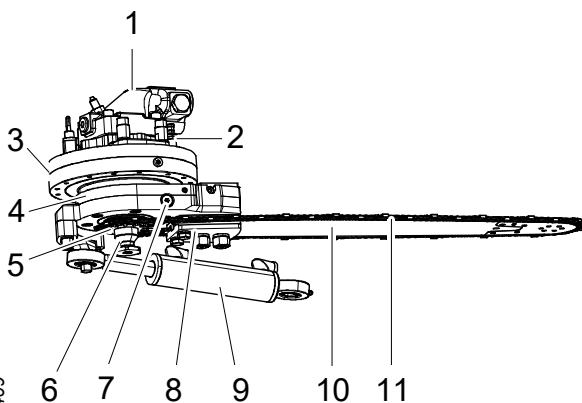

1. Saw motor
2. Home position sensor
3. Bearing unit
4. Bar mount
5. Saw chain sprocket
6. Saw chain catcher
7. Auto-release valve
8. Bar holder
9. Bar feed cylinder
10. Saw bar
11. Saw chain

2239469



### Saw 611

The saw motor's speed is controlled by a valve. The saw motor can only drive the saw chain in one direction. The saw motor speed is adjusted in the head's control system.

The bar feed cylinder is controlled by a valve.

The saw bar's outward movement is limited mechanically by the frame. The saw bar's homeward movement is limited mechanically by a stop screw. The stop screw is mounted in the frame and is also used to adjust the saw bar's home position.

Saw 611 has a manual chain tensioner consisting of a thrust washer, pin, locking shaft and excentre.

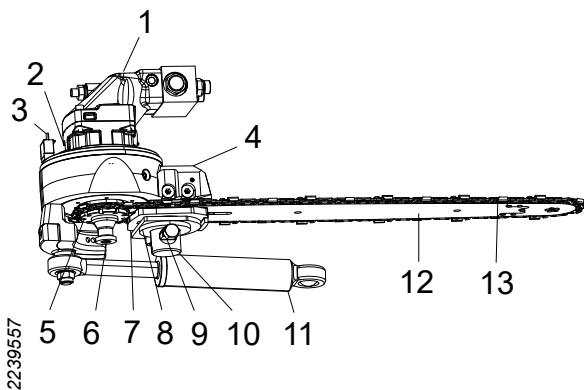

1. Saw motor
2. Cutting control sensor
3. Home position sensor
4. Bar mount
5. Saw chain sprocket
6. Saw chain catcher
7. Thrust washer
8. Excenter
9. Locking shaft
10. Pin
11. Bar feed cylinder
12. Saw bar
13. Saw chain

### Chain lubrication, Super Greasy

The Super Greasy is a hydraulic piston pump for oil-based chain lubrication. The pump is mounted on the oil tank that is integrated in the frame.

The oil tank has two strainers for primary filtration of the saw chain oil. One strainer is mounted in the oil tank under the filler cap. The other strainer is mounted in the oil tank at the inlet to the pump.

The pump has a fixed displacement. The flow rate can be varied by varying the stroke frequency (number of strokes per second). The flow is adjusted in the head's control system.

1. Lubricating pump Super Greasy

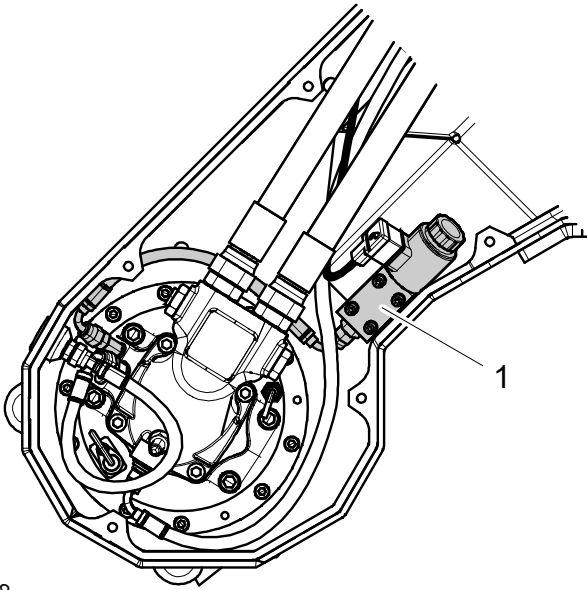

2239506

## Extra equipment

### Colour marking equipment

The colour marking equipment is used to colour-mark the timber assortment and supports two different colours.

The colour marking equipment's main components are a colour marking pump, two colour tanks and two colour marking nozzles. The colour tanks are mounted on the felling link and the colour marking pump is mounted on the frame.

The colour tanks are fitted with lids, which in turn are fitted with non-return valves. The non-return valves prevent underpressure from being generated in the tanks by letting air into the tanks as the dye is used. The non-return valves also prevent the dye from running out.

The colour marking pump is an electro-hydraulic positive displacement pump with two pistons, one for each colour. Each piston has double seals and the colour marking pump has a leakage duct between each seal pair. In this way, an external leakage occurs if one of the seals fails.

The colour marking nozzles are mounted in a colour marking block, which in turn is mounted in the frame.

When colour marking, the dye bounces off the underside of the saw bar onto the log that is being cut.

1. Right colour tank
2. Left colour tank
3. Colour marking pump
4. Colour marking block

### Find End (Root search)

The main component of the Find End system is a laser sensor mounted in the frame by the saw head. The laser beam detects the stem. The head's control system can use the signal from the laser sensor to find the end of the stem, so that the length of the stem can be measured without the stem having to be cut to reset the length measurement.

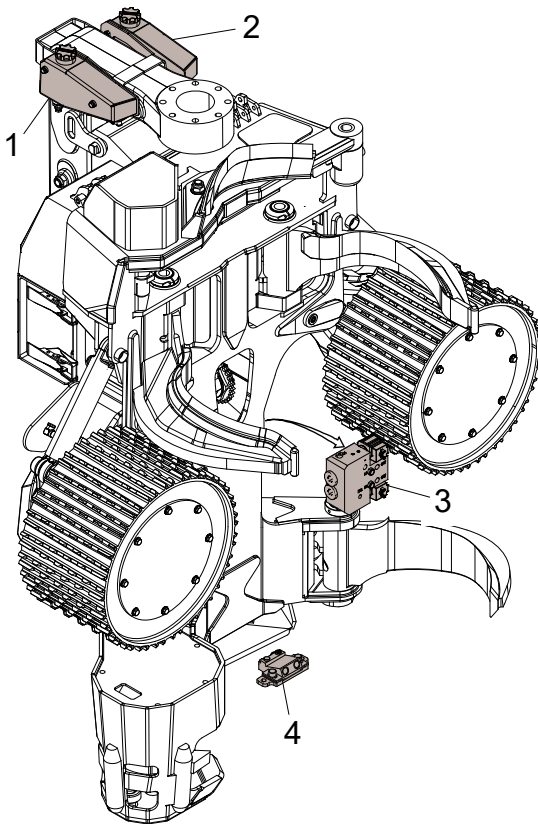

2212936

### **Stump treatment**

The stump treatment equipment sprays a pesticide on the stump to protect it against root rot.

The main components of the stump treatment equipment, such as the tank and pump, are mounted on the carrier.

The pesticide is transferred via hoses from the carrier to the saw unit, and then sprayed onto the stump via the saw bar. The saw bar must be adapted for stump treatment.

# Handling

## Transport of unattached head

**Danger!**

Crushing risk! Never walk beneath or close to suspended loads. Ensure that all lifting equipment used is in good condition, adapted for the purpose and dimensioned for the weight of the head.

**Caution!**

Risk of cuts! Dismantle the saw chains and supply the delimiting knives with blade guards when handling the head.

**Important!**

The head's incoming hydraulic connections must not be plugged when lifting the head. Connect hydraulic hoses to the hydraulic connections and route the hoses down into a collection receptacle.

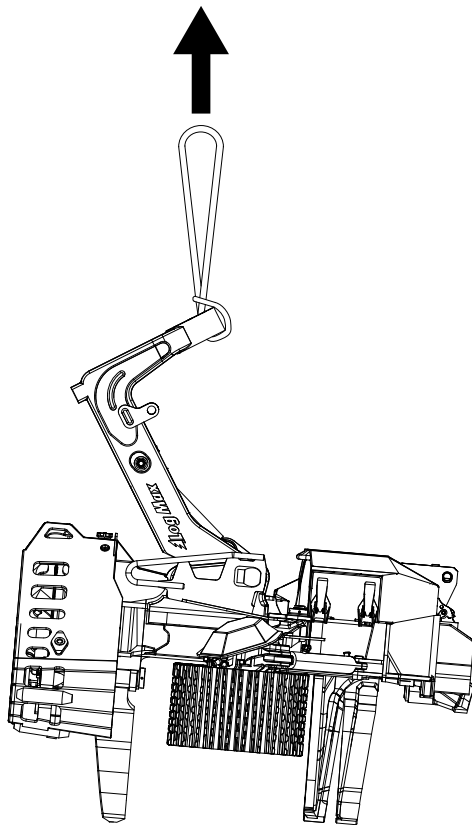

When transporting an unattached head, the head must be placed flat on a pallet. Delimiting knives and roller arms must be closed. Wooden blocks must be screwed into the pallet so that all delimiting knives and feed rollers are supported. The weight of the head must be evenly distributed between the delimiting knives and the feed rollers.

The felling link must be secured in one of its end positions. The head must be secured against the pallet.

Lift the head at the felling link as shown. Never lift at other parts of the head.

The weight of the head can be seen from “Technical data”.

### Transport of head mounted on the carrier

Transport the head according to the safety instructions for transport in the carrier’s manual.

### Storage

#### Prior to storage

If the head is to be stored and not used, the following measures must be implemented:

1. Clean the head.
2. Lubricate the head with grease at all lubrication points according to the maintenance chart.
3. Fill the oil tank with saw chain oil.
4. Refer to the maintenance section for any additional equipment with regard to instructions in the event of long breaks.

5. Operate all cylinder functions in the head between their end positions a few times to ensure that an oil film is formed on the piston rods.
6. Operate the feed roller motors for one minute in each direction to ensure they are filled with oil.
7. Install the blade guards on the delimiting knives.
8. Dismantle the saw chains.
9. If the head has an automatic saw chain tensioner, the saw bar must be moved to its innermost position and locked in place with cable ties or similar.
10. Place the head on a pallet as instructed for "Transport of unattached head".
11. Plug the head's incoming hydraulic connections so that the head remains filled with oil. If the oil is allowed to drain, hydraulic components can rust internally and be destroyed.

### During storage

#### **Important!**

The head may be stored for a maximum of 6 months. After this, the head must be used for a few hours.

Store the head indoors in an area that maintains an even temperature to avoid corrosion of the head and its electronic components.

During storage, check at regular intervals that there are no leaks. If necessary, a thin film of hydraulic oil should be applied to those piston rods that are not withdrawn into their cylinders.

### After storage

Before putting the head into operation following storage, the following measures must be implemented:

1. Check that all electrical connectors and their associated pins are free from corrosion.
2. Lubricate the head with grease at all lubrication points according to the maintenance chart.

3. Refer to the maintenance section for any additional equipment with regard to instructions in the event of long breaks.
4. Check that the saw chain lubrication is working according to the instructions for checking the saw chain lubrication.
5. Mount the saw chains.
6. Remove the delimiting knives' blade guards.

### Scrapping and recycling



#### **Warning!**

The head's accumulators are pressurised with gas, which can be released explosively in the event of external damage.

Contact the local authorities regarding how best to scrap and recycle the head.

Prior to scrapping and recycling, the following should be carried out:

- Wash the head.
- Drain the head's systems for hydraulic oil and saw chain oil into receptacles intended for this purpose.
- In cases where the head is equipped with colour marking and stump treatment: Drain the liquid from the colour marking and stump treatment systems into receptacles intended for this purpose.
- Dismantle and sort the head's electronic components.
- Dismantle and sort the head's rubber components.
- Sort the head's remaining parts as scrap metal.



# Handling

**Important!**

It is prohibited to use the head to help relieve the weight of the carrier. For example, by pushing the head against the ground to help the carrier turn around.

## Starting up the head

**Important!**

Do not use the head if the ambient temperature is below the lowest permitted temperature, see “Technical data”.

Before starting the session, proceed as follows:

1. Clean snow, ice and debris from the head.
2. Warm up the hydraulic oil according to the instructions in carrier’s manual. As a minimum, the hydraulic oil must reach the lowest permitted working temperature, see “Technical data”.

**Important!**

Do not use the feed roller motors or the saw motor to warm up the hydraulic oil, as this could damage the motors.

3. If the saw unit has a manual chain tensioner: tension the saw chain according to the instructions for the saw unit.
4. Operate the head’s hydraulic functions a few times so that the head is supplied with warm hydraulic oil.

**Important!**

Allow the head to work with limited pressure and flow when the head’s hydraulic functions are being operated to provide the head with warm hydraulic oil.

5. Check that the saw chain lubrication is working according to the instructions for checking the saw chain lubrication.

### Felling work

**Danger!**

The head must be completely closed around the stem before felling the tree. If the head moves during sawing, there is a risk of chain shots.

**Danger!**

Never leave a tree that has been almost cut through without taking other measures.

**Danger!**

Note the felling direction! The head cannot force the tree to fall in a particular direction. When the tree has been cut through and has started to fall, it is basically impossible to change the felling direction.

**Danger!**

Risk of injury. Never feed the stem towards the cab.

**Important!**

Operate the head using gentle movements to minimise wear on the head and the carrier.

The felling process using the head can be split into sub-elements: planning, felling, processing and sorting.

### Planning

Plan the felling work before starting. Position the carrier with respect to:

- distance to the trees that are to be processed.
- stacking location.
- felling direction.
- that the carrier is stable.

### Felling

Select the felling direction so that the tree is felled safely in the desired direction. Give consideration to:

- wind direction and wind strength.
- the incline of the tree and the land.
- nearby trees and other obstacles.

Apply the head on the opposite side from the side towards which the tree is to be felled. Grip the tree as low as possible, but make sure that the saw bar can cut the entire stem. Double cuts may be made, if necessary. In those cases where the cutting control sensor prevents the saw bar from cutting through the entire stem, manual cutting can be performed.

#### **Important!**

Do not turn the head with the rotator after the tree has been cut through and has begun to fall, as this can damage the rotator.

#### **Important!**

Under no circumstances may the head be reversed down towards the root. This can damage the mountings for the knives and feed rollers, making the head unusable.

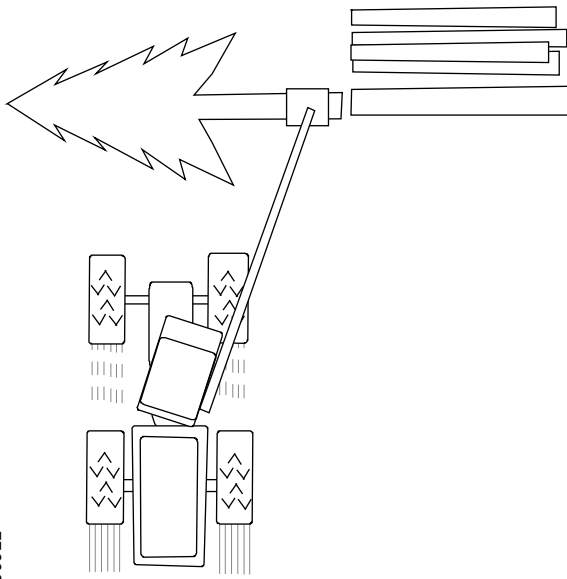

900922

Press the head gently against the tree in the felling direction. This makes felling easier and reduces the risk of the saw bar sticking. If the head is pressed too hard against the tree, felling cracks can occur in the timber.

Do not break off a tree that has been cut halfway through, rather saw through the entire tree in order to minimise the risk of felling cracks.

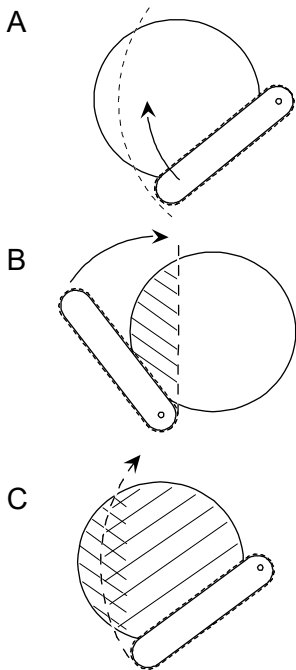

900935

## Double cutting

Double cutting is a technique that is used when felling thick trees where the saw bar is unable to cut through the stem with one cut (figure A). In this case, two cuts can be made from two different directions to get through the stem.

First make a cut with the head turned 90° clockwise (figure B) in relation to the intended felling cut.

Before making the second cut, turn the head to the position for the felling cut. After completing this cut, the tree will have been sawn through (figure C). The tree will fall, even though the two cuts do not meet exactly.

## Processing and sorting

Processing involves delimiting trees and cutting them into appropriate lengths. Well planned and executed processing maximises the timber value, makes haulage easier and reduces damage to the ground.

Process trees so that the timber ends up in piles sorted by timber quality. Aim with the head above the previously cut logs when processing. The logs are then cut so that their ends are aligned with each other. This is known as evening the log-ends in the timber piles. If possible, cut the log with support to minimise the risk of cutting cracks.

Avoid laying branches and twigs on timber that has been processed. If the ground has a low bearing capacity, it is advisable to perform delimiting in front of the carrier so that the brushwood protects the ground from driving damage and prevents the carrier from becoming stuck.

**Thick branches**

If the tree has one or more thick branches that can make processing more difficult, the tree can be delimited in a single operation or be delimited a little further than the intended log length. This is done to allow the head to achieve a high feed rate, which makes the delimiting of trees with thick branches easier. The log is then reversed and processed as normal.

**Forks**

The technique for handling trees with forks depends on the appearance of the tree.

If the fork is low down, one stem section is cut off directly and processed as normal. The rest of the tree is then felled and processed.

If the fork is high up, the entire tree is felled and processed as normal up to the fork. The stem is then placed on the ground. Position the head suspended above the fork and activate the saw unit to cut off one or both parts of the stem. Then pick up and process the stem parts as normal.

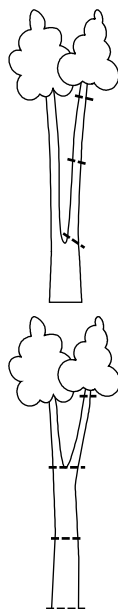

900948

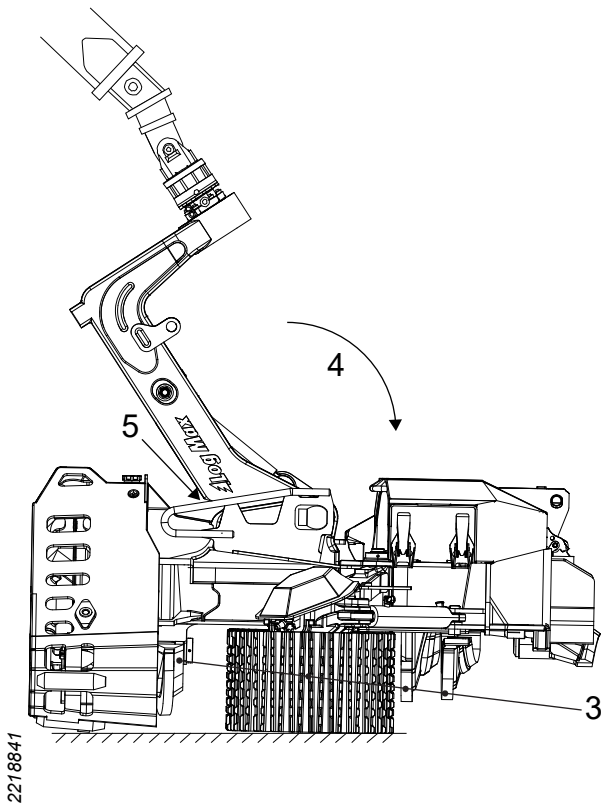

## Parking on completion of the work

1. If the saw unit has a manual saw chain tensioner: release the saw chain's tension in line with the inspection and maintenance for the saw unit.
2. Roughly clean the head in accordance with "Rough cleaning".
3. Close the delimiting knives and open the feed roller arms.
4. Place the head in floating mode and lower it onto a firm, flat surface.
5. Angle the felling link towards the mechanical stop in the frame.
6. Relieve the load on the carrier's hydraulics.
7. Turn off the carrier. Remove the start key and disconnect the main power.

Observe the safety instructions in the carrier's manual regarding parking the carrier.

## Unforeseen operational stoppages



### Danger!

Always try to remedy the fault from the carrier's cab. Only leave the cab as a last resort when you have made sure that no unexpected machine movements can occur.



### Danger!

Never attempt to release stems by hand that have become stuck in the head, for example by loosening hydraulic hoses or manually activating the head's hydraulic valves.

In the event of a failure, such as hose or cable rupture, which makes the head unusable and where the head is still gripping a stem, the head must be released from the stem before commencing repair work.

Position the head so that the delimiting knives are free from the ground. Try activating the function to open the delimiting knives.

If the delimiting knives do not open, disconnect the pressure supply to the head. Wait until the delimiting knives have opened slightly with the aid of the internal leakage in the head's hydraulic valves. Then use the carrier's crane to prise the head away from the stem.

Use other machinery if necessary.





## Inspections and maintenance

This chapter describes inspections and maintenance of the head that can be performed by the driver. All maintenance work on the head for which there are no instructions in this chapter must be carried out by technicians possessing the requisite knowledge.

Some of the operations in this chapter require two people in order to be performed. Make sure that it is possible to call for help in the event of an accident. Always have a mobile phone, communication radio or similar close at hand when conducting inspections and maintenance work. Also ensure that suitable vehicles and navigable roads are available in the event it becomes necessary to go to a hospital.

**Danger!**

Crushing risk! The head must be parked as instructed to minimise the risk of crushing injuries.

**Warning!**

Risk of burns! Allow the head and hydraulic oil to cool before performing inspections and maintenance on the head.

**Warning!**

The head's hydraulic system is fitted with accumulators. Pressure may remain in the system for some time after the pressure supply has been interrupted.

**Warning!**

Pressurised liquid can cause cuts. Never search for leaks in the head's systems by feeling with your hands or other parts of your body.

**Warning!**

Risk of cuts! Always dismantle all saw chains and install blade guards on the delimiting knives before starting inspections and maintenance of the head.

**Warning!**

Risk of eye injury! Laser beam. Do not look into the beam. Class 2 laser product.

**Caution!**

Avoid skin contact with the head's liquids, as they can be harmful. Also avoid inhaling fumes.

## Parking the head prior to inspections and maintenance

### Parking in the tilted up position

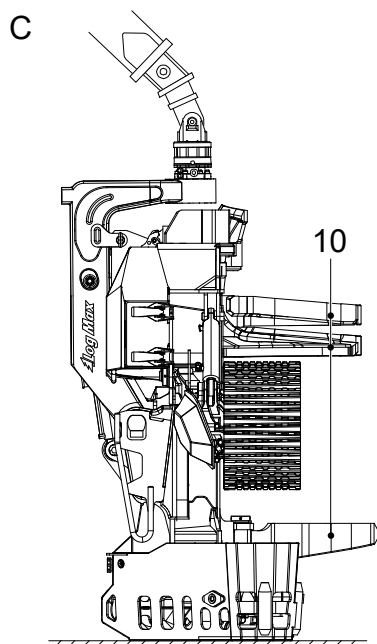
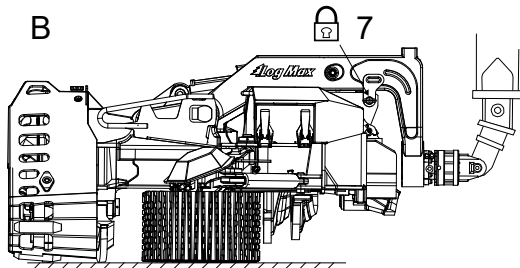
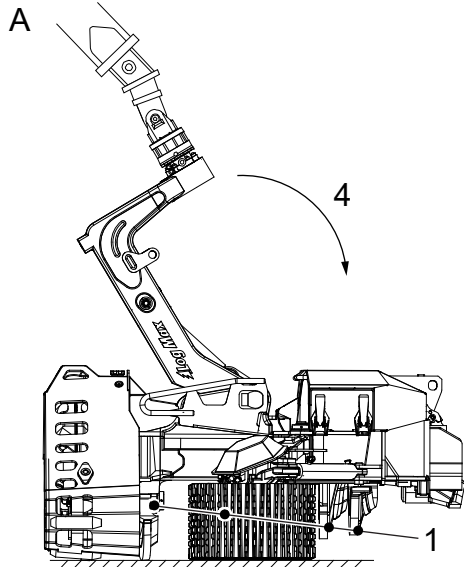

- A**
- 1 Close the delimiting knives and open the feed roller arms.
  - 2 Set the head in floating mode.
  - 3 Place the head on a firm, flat surface.
  - 4 Carefully run out the crane so that the felling link is positioned against its upper stop position.
  - 5 Relieve the load on the carrier's hydraulics.
  - 6 Turn off the carrier. Remove the start key and disconnect the main power.
- B**
- 7 Lock the felling link against the frame using the safety pin.
  - 8 Start the machine.
- C**
- 9 Carefully raise the head with the aid of the crane.
  - 10 Open the delimiting knives.
  - 11 Place the head on a firm, flat surface.
  - 12 Relieve the load on the carrier's hydraulics.
  - 13 Turn off the carrier. Remove the start key and disconnect the main power.
  - 14 Install the blade guards on the delimiting knives.
  - 15 Dismantle all saw chains.

Observe the safety instructions in the carrier's manual regarding parking the carrier.

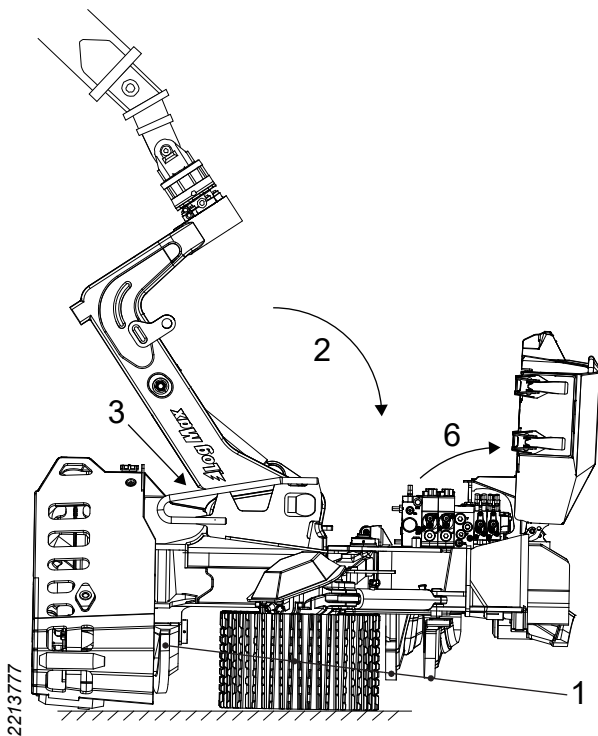

### Parking in the tilted down position

1. Close the delimiting knives and open the feed roller arms.
2. Set the head in floating mode and park it on a firm, flat surface.
3. Angle the felling link backwards towards the mechanical stop.
4. Relieve the load on the carrier's hydraulics.
5. Turn off the carrier. Remove the start key and disconnect the main power.
6. Open the protective cover on the head and disconnect the electric cable for the *tilt up* function.
7. Install a blade guard on the upper delimiting knife.

Observe the safety instructions in the carrier's manual regarding parking the carrier.

### Rough cleaning

Park the head in accordance with "Parking in the tilted up position".

Roughly clean the head as shown below.

1. Remove branches and tree remnants from the head. Check that they have not caused any damage.
2. Clean the head of water and snow in cold weather to prevent ice formation.
3. Clean the measuring wheel and around the measuring wheel arm.
4. Clean the feed rollers.
5. Clean the saw unit.

### Inspecting the head

Park the head in accordance with "Parking in the tilted up position", unless otherwise indicated.

### **Make sure that the head does not have any cracks**

To check that the head does not have any cracks:

1. Remove the right and left protective plates by the right and left delimiting knives.
2. Check for cracks in the head's components. Be careful to check:
  - the frame, especially at all cylinder attachments.
  - the felling link.
  - the feed roller arms.
  - the delimiting knives.

If cracks are found, the affected components must be repaired before the head is put into operation. See section for "Repair welding".

3. Reinstall the right and left protective plates by the right and left delimiting knives.
4. Make sure that all guards are intact. Check that the screws holding the guards are intact and tightened. Replace screws that have fallen out.

### **Inspecting stop buffers**

Check that the stop buffers by the felling link and the feed roller arms are not damaged or missing. Replace damaged and missing stop buffers.

### **Inspecting electrical wiring**

Park the head in accordance with "Parking in the tilted down position".

Open the protective cover and check that the visible electrical wiring is intact and undamaged. Replace damaged or defective electrical wiring.

#### **Important!**

Replacement of electrical wiring must be carried out by technicians possessing the requisite knowledge.

### Inspecting wear plates

Park the head in accordance with “Parking in the tilted up position”.

#### Wear plate at top saw

When the wear plate at the top saw is worn down to half the thickness of the material, it must be replaced in accordance with Repair welding.”

#### Upper wear plate

When the upper wear plate is worn down to half the thickness of the material, it must be replaced in accordance with “Repair welding”.

#### Lower wear plate

When the lower wear plate is worn down to half the thickness of the material, it must be replaced in accordance with “Repair welding”.

### Inspecting and adjusting the protective cover and over-centre latches



#### Warning!

Risk of crushing injuries! The protective cover is heavy and has sharp edges. It must be handled with care.

Park the head in accordance with “Parking in the tilted down position”.

Check that the gas spring is intact. Check that the screws securing the over-centre latches are intact and tightened.

Check that the protective cover’s over-centre latches are intact. Check that the screws securing the over-centre latches are intact and tightened. Replace screws that have fallen out.

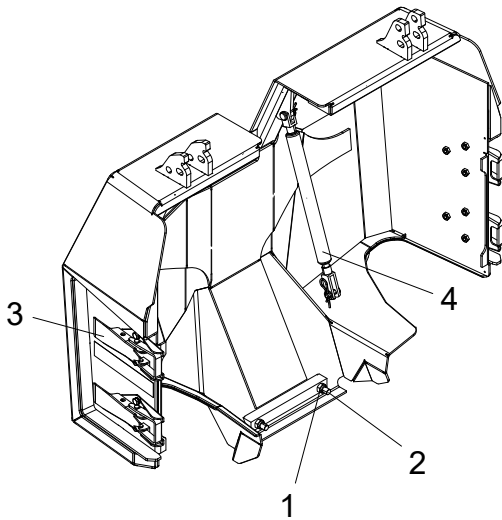

2215005

Adjust the protective cover's stop screws and locking nuts so that the protective cover is secure when the over-centre latches are locked and so that no over-centre latches are loose.

1. Locking nuts
2. Stop screws
3. Over-centre latches
4. Gas springs

### Shafts for felling link, feed roller arms and delimiting knives

Park the head in accordance with "Parking in the tilted up position".

#### Inspecting Log Max's standard shafts

Make sure that the shaft's locking screw is intact and tightened.

Check that the shaft's rotation locking is intact. If necessary, repair in accordance with "Repair welding"

#### Check of Expander

Check that the Expander axle is centred in its position and that there is no play.

If the Expander axle is dismantled or has moved, the Expander axle must be treated as a new Expander.

#### Torqueing the Expander

Mark the Expander axle's position in relation to the frame. Torque the Expander axle crosswise and incrementally to the recommended torque per "General tightening torque for Expander".

### New Expander

A new or removed Expander must be tightened cross-wise:

1. Torque the Expander axle per "Torqueing theExpander".
2. Run the function between its end positions 10 times.
3. Torque the Expander axle per "Torqueing theExpander".
4. Repeat torqueing after 8 hours.
5. Repeat torqueing after 40hours.
6. Repeat torqueing every 40 hours until the Expander axle no longer moves when tightened. Thereafter, the torque is checked per the maintenance chart.

### Inspecting axial play

To check the axial play between a component and the frame:

1. Park the head in accordance with "Parking in the tilted up position".
2. Dismantle the protective plates by the right and left delimiting knives.
3. Use a feeler gauge to check the gap between the component and the frame. Note the gap on both sides of the component.
4. If the total gap exceeds 1 mm, the shaft must be shimmed.

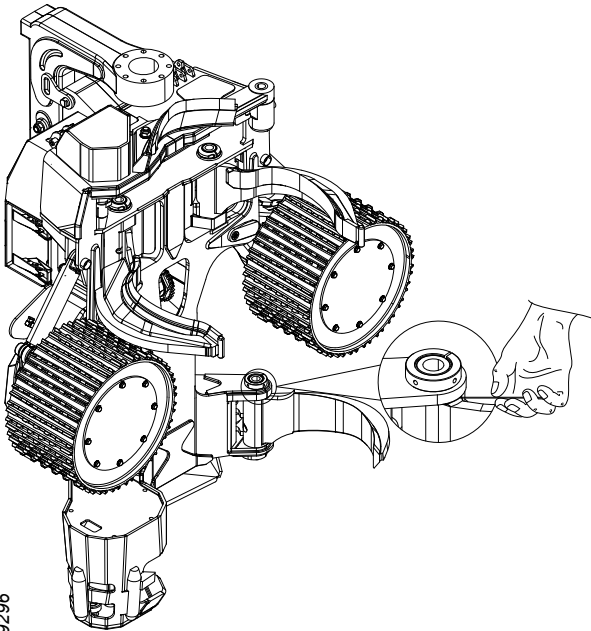

2219296

### Important!

Shimming of shafts must be carried out by technicians possessing the requisite knowledge.



## Delimiting unit



### Caution!

Risk of cuts. The edges of the delimiting knives are sharp.

Park the head in accordance with "Parking in the tilted up position".

### Delimiting knives' edges

Minor damage to the delimiting knives' edges is remedied with a hammer and file. Major damage is remedied with a grinding disc for metal in a grinding machine. In order for the delimiting knives to retain their hardness, they must not be exposed to high temperatures during grinding.

For easy control of the correct edge angle, an edge template is available. The edge template can be used for all the delimiting knives' edges, except for the counter-chamfers of the lower delimiting knife.

### Important!

Replacement of delimiting knives must be carried out by technicians possessing the requisite knowledge.

901449

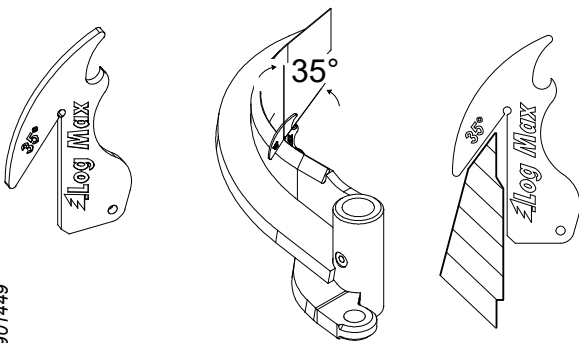

906658

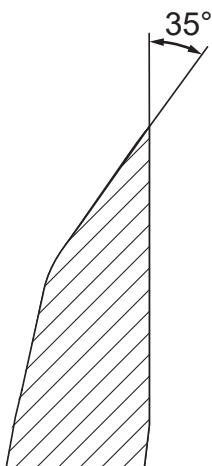

### Upper delimiting knife

The upper delimiting knife must be sharpened according to the edge template. If the upper delimiting knife acquires a counter-chamfer or becomes worn on the inside, repair welding can be performed in accordance with "Repair welding" and the blade can then be sharpened again. When the knife blade on the upper delimiting knife becomes too worn, the knife blade is replaced according to "Repair welding".

### Right and left delimiting knives

The right and left delimiting knives must be sharpened according to the edge template.

When the knife blades on the right and left delimiting knives become too worn, or the thickness of the knife blade is less than 8 mm, they must be replaced according to "Repair welding". The wear limit for the right and left delimiting knives is measured at (1).

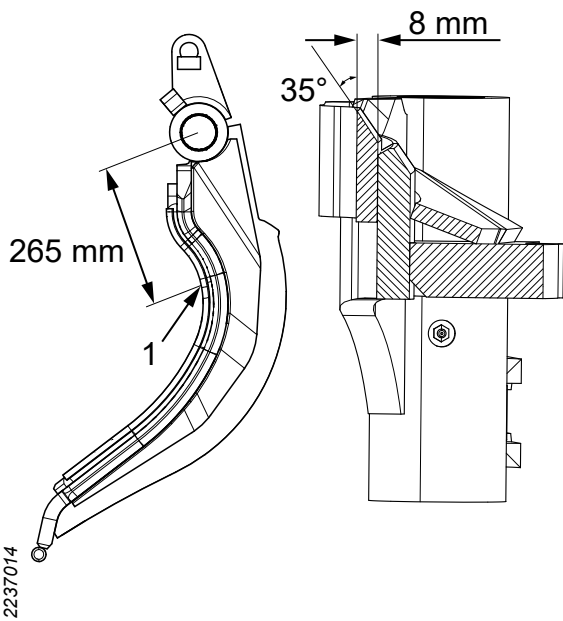

### Lower delimiting knife

The upper and lower edges of the lower delimiting knife must be sharpened according to the edge template, but with a counter-chamfer (1).

When the lower delimiting knife is sufficiently worn, it must be replaced. The wear limit is when the total height of the lower delimiting knife is less than 132 mm or the thickness is less than 17 mm.. The wear limit for the lower delimiting knife is measured at (2).

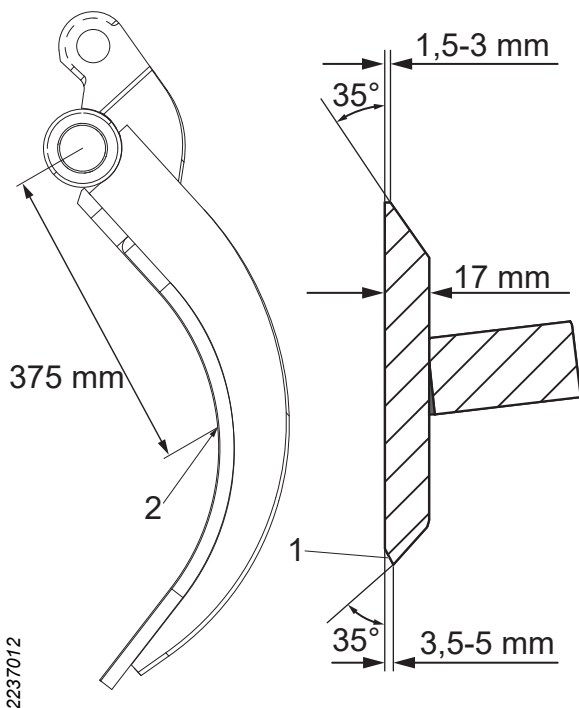

### Fixed delimiting knife

The fixed delimiting knife does not need to be maintained. It is integrated into a wear plate that is replaced when it is worn out, see "Inspecting wear plates".

### Upper delimiting knife's spring and its preload

To check the spring for the upper delimiting knife and its preload, check first that the spring (1) is intact. If the spring is damaged or worn, replace the spring according to "Replacement of the upper delimiting knife's spring".

Adjust spring preload as follows:

1. Loosen the locking nut (2).
2. Turn the adjustment screw (3) clockwise to increase the preload.
3. Turn the adjustment screw (3) anti-clockwise to decrease the preload.
4. Tighten the locking nut (2).

During basic setting of spring preload, the adjustment screw (3) must protrude approximately 4 mm from the threaded plug.

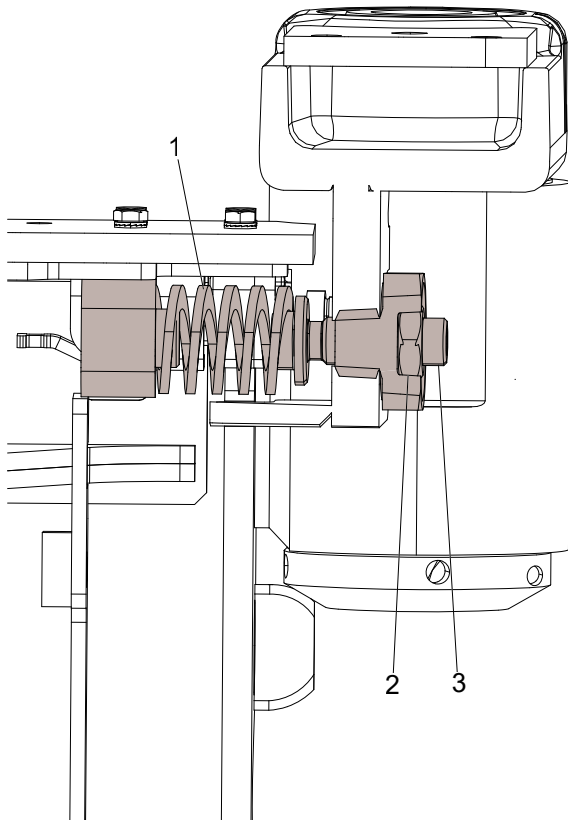

2006980

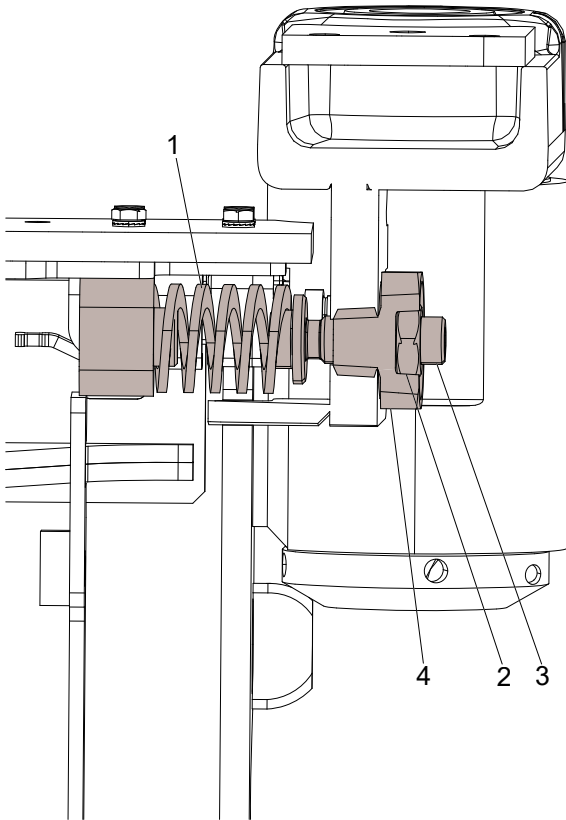

2097822

### Replacement of the upper delimiting knife's spring

When the spring for the upper delimiting knife is worn or damaged, it must be replaced as follows:

1. Loosen the locking nut (2).
2. Turn the adjustment screw (3) anti-clockwise until it is fully unscrewed.
3. Loosen the threaded plug (4).
4. Pull the upper delimiting knife to its outer end-position.
5. Replace the old spring (1) with a new spring.
6. Screw the threaded plug (4) back in.
7. Screw in the adjustment screw (3) so that the spring (1) remains in place.
8. Push back the upper delimiting knife.
9. Adjust the default setting of the spring preload according to "Upper delimiting knife's spring and its preload".

### Basic setting and adjustment of upper delimiting knife sensor



#### **Danger!**

Only the ignition may be activated when the basic setting of the upper delimiting knife is performed. Make sure that the carrier's other functions cannot be activated.

The correct setting of the upper delimiting knife sensor is necessary in order for the head's delimiting and feed unit to function properly. It is therefore important to adjust the upper delimiting knife sensor according to the prevailing conditions.

### Active Friction Control™ (AFC)

This instruction describes how to conduct a mechanical basic setting of the upper delimiting knife sensor. Proper setting of the AFC system also requires adjustment of settings in the head's control system.

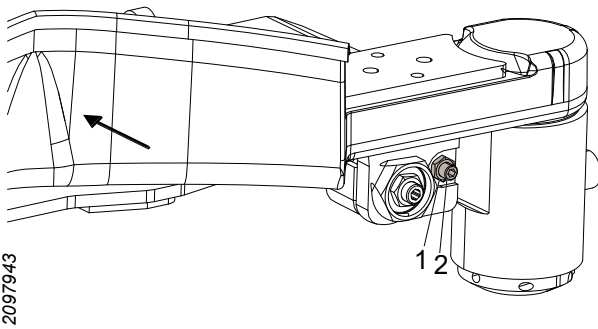

1. Loosen the adjustment screw's locking nut (1).
2. Rotate the adjustment screw (2) anti-clockwise as far as possible.
3. Press and hold the upper delimiting knife against its stop lug.
4. Turn the adjustment screw (2) clockwise until it makes mechanical contact with the upper delimiting knife sensor.
5. Turn the adjustment screw (2) anti-clockwise 1 turn.
6. Lock the adjustment screw (2) with the locking nut (1). Take care not to turn the adjustment screw (2) when tightening the locking nut (1).

For further instructions regarding the adjustment of the AFC system, refer to the manual for the head's control system.

### Checking and adjusting the upper delimiting knife's screw and nut in the groove

Check that the screw and nut are intact and that the upper delimiting knife is in contact with the frame. In order for the upper delimiting knife to be able to move, a play (1) of 0.3-0.7 mm is required. The play (1) is checked with a feeler gauge.

Adjust the play (1) using shims.

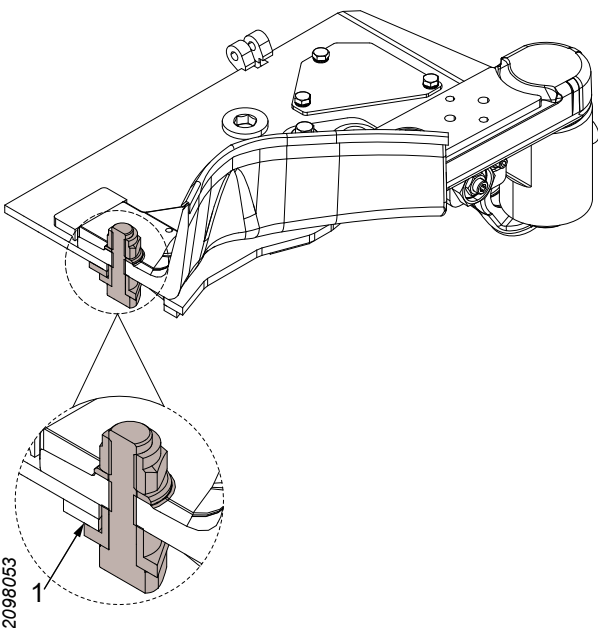

### Important!

If the play is too great, the upper delimiting knife and frame can be damaged.

### Feeding unit

Park the head in accordance with "Parking in the tilted up position".

### **Inspecting feed rollers**

Check the sharpness and wear of the feed rollers' ribs. Sharpen or replace the feed rollers if necessary. Replace the feed rollers according to "Replacement of feed rollers".

### **Tightening feed roller nuts**

Tighten the feed roller nuts crosswise to the recommended tightening torque:

V12  
200 Nm.  
MS11  
550 Nm.

If tightening is performed using hand tools, the feed roller must be blocked so that it cannot rotate.

If the feed roller has recently been installed, tightening must be repeated after 1 h.

## **Replacement of feed rollers**

### **Removing feed rollers**

In order to remove a feed roller:

1. Loosen the feed roller nuts  $\frac{1}{2}$ -1 turn. If the nuts are loosened using hand tools, the feed roller must be blocked so that it cannot rotate.
2. Secure the feed roller with suitable lifting equipment.
3. Remove the feed roller nuts and the feed roller.

### **Installing feed rollers**

To install a feed roller:

1. Clean the feed roller's and the feed roller motor hub's mating surfaces.
2. Clean and check threads in the feed roller nuts and on the feed roller motor hub's screws. Replace damaged nuts and screws.

### **Important!**

Replacement of screws in the feed roller motor hub must be carried out by technicians possessing the requisite knowledge.

3. Lift the feed roller into position using suitable lifting equipment.

### **Important!**

Lubricate the feed roller motor hub's screws before installing the feed roller nuts.

4. Secure the feed roller by installing the feed roller nuts and tightening them gently.
5. Remove the lifting equipment.
6. Tighten the feed roller nuts according to "Tightening feed roller nuts".

### **Checking the tightening of screws for feed roller motors**

To check that the screws holding the feed roller motors are tightened:

1. Remove the feed rollers according to "Removing feed rollers".
2. Tighten the screws holding the feed roller motors crosswise to the recommended general tightening torque for oiled steel screw joints with Nord-Lock washers, see "Technical data".
3. Install the feed rollers according to "Installing feed rollers".

### **Diameter measurement unit**

Check the diameter measurement unit's sensors by opening and closing the feeder roller arms five times. The sensors' value in the control system must not differ by more than 5 pulses in the repetitions for open or closed position. If the value differs by more than 5 pulses, the diameter measurement unit is defective and troubleshooting must be performed by technicians possessing the requisite knowledge.

Refer to the control system's manual for more information.

### **Important!**

Replacement of sensors must be carried out by technicians possessing the requisite knowledge.

## **Length measurement unit**



### **Caution!**

The measuring wheel is sharp. Wear suitable protective equipment when working with or near the measuring wheel.



### **Warning!**

Risk of crushing injuries. Work with the length measurement unit takes place in confined spaces and involves moving parts.

### **Important!**

Replacement of sensors must be carried out by technicians possessing the requisite knowledge.

Park the head in accordance with "Parking in the tilted up position".

## **Inspecting the length measurement unit**

Check the mechanical parts of the length measurement unit:

1. Press and hold the inside button for *length measurement wheel out* and shut down the base machine.
2. Pull out the measuring wheel arm.
3. Check the wear on the measuring wheel tracks. If necessary, replace in accordance with "Replacing measuring wheel tracks"



4. Check the measuring wheel's rolling resistance by rotating the measuring wheel by hand. The rolling resistance for the measuring wheel even. If the rolling resistance is uneven or if the measuring wheel rolls too easily, the measuring wheel's bearing must be adjusted.
5. Check for play in:
  - the measuring wheel's bearing.
  - the measuring wheel arm attachment to the frame.

If there is play, the affected component must be replaced.

### **Important!**

The renovation of the measuring wheel's bearing or the replacement of components in the length measurement unit, other than measuring wheel tracks, must be carried out by technicians possessing the requisite knowledge.

### **Replacing measuring wheel tracks**

In order to replace measuring wheel tracks:

1. Press and hold the inside button for *length measurement wheel out* and shut down the base machine.
2. Pull out the measuring wheel arm.
3. Remove the screws holding the measuring wheel tracks against the measuring wheel arm's hub and remove the measuring wheel tracks.
4. Install new measuring wheel tracks with new screws and washers.
5. Test-operate the head and check that the measuring wheel is free from:
  - the frame.
  - the feed rollers when the feed roller arms are closed.

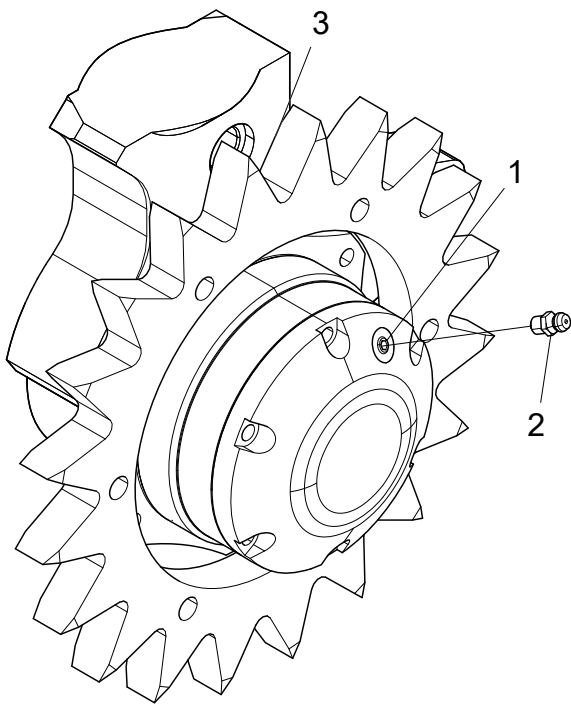

### Lubricate the measuring wheel bearings

1. Unscrew the threaded plug (1).
2. Screw the grease nipple (2) into place.
3. Lubricate the measuring wheel bearings with grease until the grease emerges from the back (3) of the measuring wheel bearing.
4. Turn the measuring wheel half a turn and lubricate again until the grease emerges from the back (3) of the measuring wheel bearing.
5. Unscrew the grease nipple (2).
6. Screw the threaded plug back in (1).

2230377

### Saw unit



#### **Danger!**

The risk of chain shots increases if saw unit's components are worn. You must therefore check regularly that the saw chain, saw bar, saw chain sprocket and chain shot guard are in good condition.



#### **Danger!**

Always discard the broken saw chain after a breakage.



#### **Danger!**

If the saw chain catcher or the screw that is securing it to the saw motor shaft should fail, the saw chain sprocket can be thrown out at high speed.



### Warning!

Always use suitable protective equipment when handling the saw chain, saw bar and saw chain sprocket.

### Important!

Risk of saw motor failure. Never operate the saw motor unloaded for longer than a total of 3 seconds per full minute.

### Important!

Replacement of sensors must be carried out by technicians possessing the requisite knowledge.

Park the head in accordance with “Parking in the tilted up position”, unless otherwise indicated.

### Inspecting chain shot guard

Check that the chain shot guard is not damaged. If the chain shot guard has sustained damage that is deeper than 2 mm, the chain shot guard must be replaced.

### Important!

Replacement of the chain shot guard may only be carried out by technicians possessing the requisite knowledge.

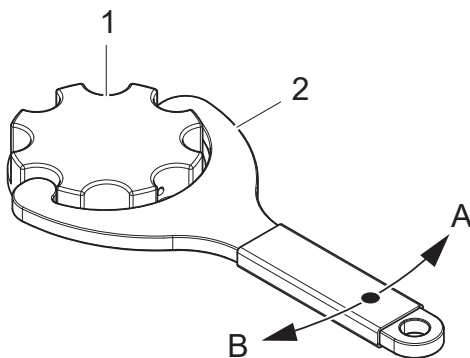

### Fill with saw chain oil

Top up the saw chain oil every 8 hours or as necessary.

1. Tank filler cap
2. Tool for tank filler cap

- A Open
- B Close

Clean the strainers in the oil tank if necessary.

### Checking saw chain lubrication

Activate the lubricating pump in the control system and check that saw chain oil reaches the saw bar. If saw chain oil does not reach the saw bar, troubleshooting is required.

### Inspecting saw chain

Check the tensioning of the saw chain. Refer to the instructions for the relevant saw unit.

Check the cutting angles, the sharpness and any damage to the saw chain. Replace the saw chain if damage is present. The correct cutting angles and sharpness reduce wear on the saw bar and saw chain, and counteract cutting cracks in the timber.

#### **Important!**

Always check and sharpen the saw chain according to the saw chain manufacturer's recommendations.

### Inspecting saw bar

Check and clean the saw bar's saw chain track and saw oil ducts so that they do not become clogged with sawdust and tree remnants.

Turn the saw bar at regular intervals so that the bar wears evenly on both sides.

#### **Important!**

Do not cut for longer than approx. 5 seconds at a time. Otherwise there is a risk of the saw bar becoming too hot and potentially becoming hardened. A hardened saw bar becomes brittle, which can lead to cracks or to pieces of the saw bar becoming detached.

Replace the saw bar if:

- the saw bar is bent.
- the saw bar has cracks or other damage.
- the bar rails begin to develop burrs and the wear surfaces show traces left by the saw chain.

- the saw bar has hardened.
- there is play in the nose sprocket.

To replace the saw bar, refer to the instructions for the relevant saw unit.

### Inspection of saw chain sprocket and saw chain catcher

Check the saw chain sprocket's wear and damage. Replace the saw chain sprocket if necessary.

If saw unit has a saw chain with:

- 0.404" pitch, the saw chain sprocket must be replaced after a maximum of 10 spent saw chains or when the wear depth in the saw chain sprocket's surface reaches 0.6 mm.

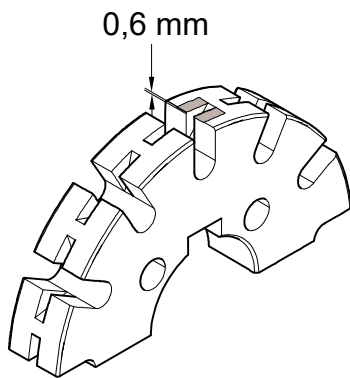

2239540

If saw unit has a saw chain with:

- 3/4" pitch, the saw chain wheel must be replaced when the wear depth on the saw chain wheel surface reaches 0.6 mm, or when the cogs on the gears (1) are worn down to the outer diameter of the saw chain wheel.

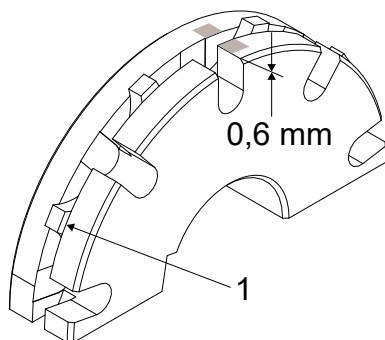

2222102

Check that the saw chain catcher is not damaged.

Replace the saw chain catcher if:

- it is heavily worn.
- it has cracks.
- chips have become detached.
- there is play between the saw chain catcher and the saw motor shaft.

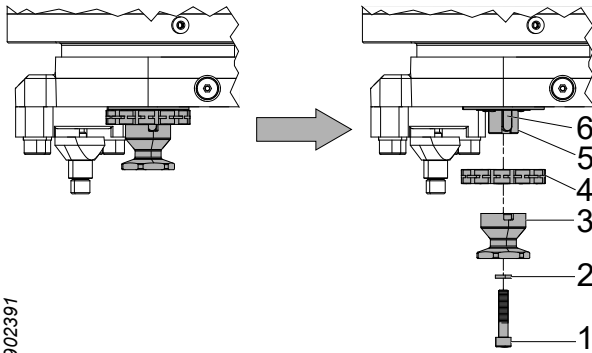

### Replace saw chain sprocket and saw chain catcher

1. Dismantle the saw chain according to the relevant saw unit's instructions for replacing the saw chain.
2. Remove the screw (1) and the washer (2) and discard them.
3. Dismantle the saw chain catcher (3).
4. Dismantle the saw chain sprocket (4).
5. Check that the saw motor shaft (5) and the shaft wedge (6) are not damaged. Replace the shaft wedge (6) if there is play between the saw motor shaft (5) and the shaft wedge (6). If there is play even though a new shaft wedge (6) has been installed, the saw motor shaft (5) must be replaced.
6. Clean and lubricate the saw motor shaft (5) with grease or oil.
7. Install a new saw chain sprocket (4). Check that the saw chain track in the saw chain sprocket is in line with the saw bar's saw chain track. Adjust the saw chain sprocket with shims if necessary.
8. Install the saw chain catcher (3), a new washer (2) and a new screw (1).
9. Install the saw chain according to the relevant saw unit's instructions for replacing the saw chain.

#### **Important!**

Replacement of the saw motor or saw motor shaft may only be carried out by technicians possessing the requisite knowledge.

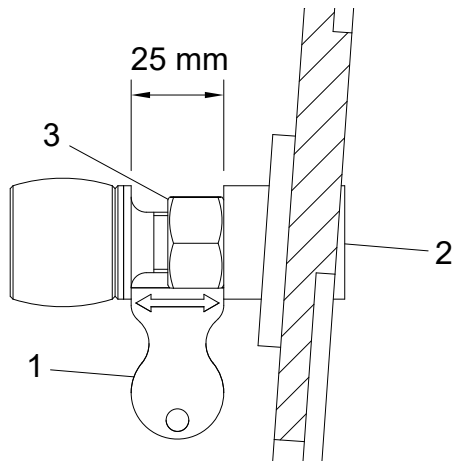

2761879

### Checking the stop screw

Check that the stop screw is not damaged or missing. Replace a damaged or missing stop screw.

### Replacing the stop screw

1. Remove the stop screw.
2. Fit the new stop screw.
3. Use tool (1) to set the home position. Adjust the distance between the stop screw and the frame with an Allen key (2).
4. Lock the stop screw with the nut (3).

### Important!

The screw at the stop buffer is glued and must not be used to adjust the stop screw.

## Saw 318

### Tension saw chain

Saw 318 has an automatic saw chain tensioner that tensions the saw chain when the head is supplied with hydraulic pressure.

### Replace saw chain

1. Push in the saw bar.
2. Disengage the saw chain from saw bar's nose sprocket and the saw chain sprocket.
3. Install a new saw chain.

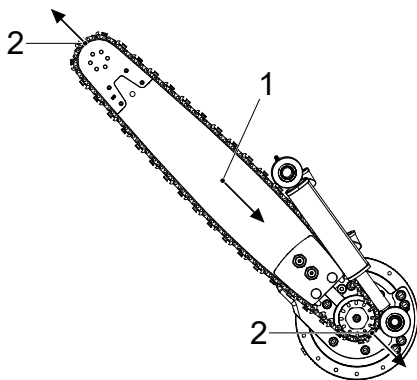

902608

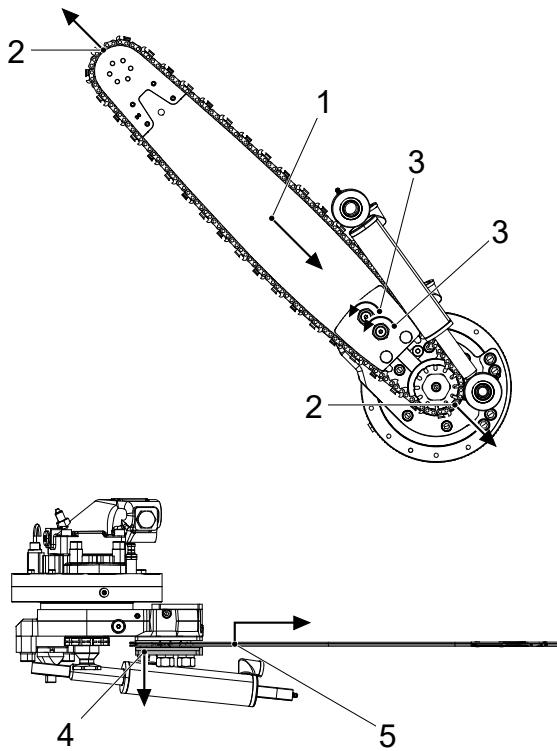

### Replace saw bar

1. Push in the saw bar.
2. Disengage the saw chain from saw bar's nose sprocket and the saw chain sprocket.
3. Loosen the nuts in the bar holder. Loosen so that the saw bar is free from the guide pins in the bar holder.
4. Pull down the bar holder's lower plate in order to release the saw bar.
5. Lift the saw bar so that it is free from the guide pins in the bar holder and pull out the saw bar.
6. Install a new saw bar, making sure that the guide pins are fitted into the corresponding holes in the saw bar.
7. Tighten the nuts in the bar holder so that the saw bar is clamped in place.
8. Install the saw chain.

### Cleaning behind the bar holder

#### Important!

Make sure that the spring-loaded pistons within the tensioning pistons remain in place when the bar holder is dismantled.

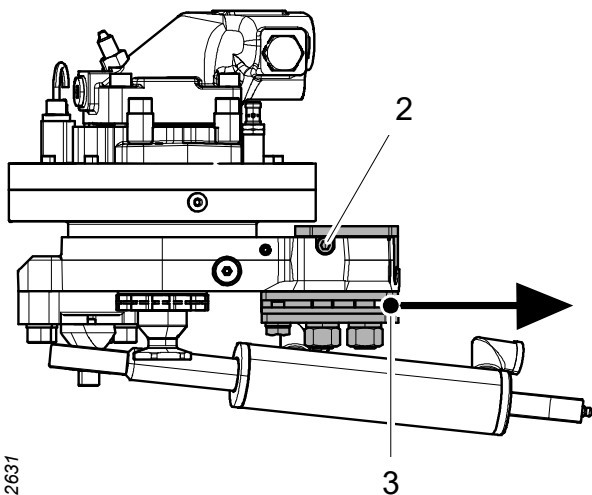

1. Dismantle the saw bar according to "Replace saw bar".
2. Loosen the two stop screws on the bar mount.
3. Remove the bar holder and gently clean the tracks for the bar holder.
4. Reinstall the bar holder and tighten the stop screws.
5. Install the saw bar according to "Replace saw bar".



## Saw 611

### Tension saw chain

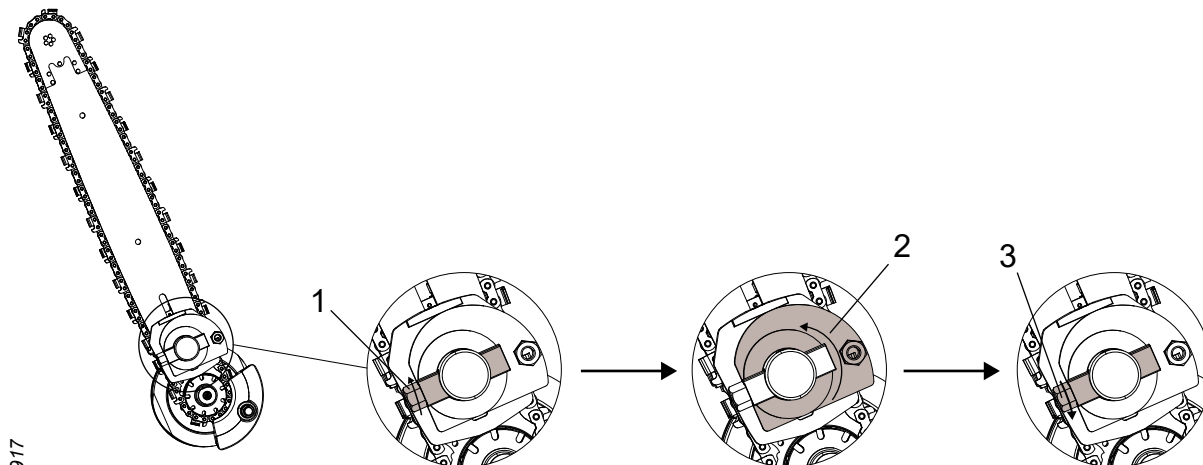

2222917

1. Loosen the preload on the saw bar by turning the locking shaft anti-clockwise. The locking shaft does not need to be rotated further than the point where the preload is released.
2. Tension the saw chain by turning the cam anti-clockwise so that the saw bar is pressed out against the saw chain.
3. Secure the saw bar by turning the locking shaft clockwise.

#### Important!

At the end of the work, the saw chain's tension must be released so that the saw chain can shrink when it cools.

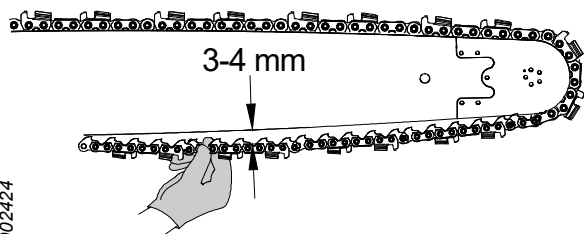

902424

#### Check the saw chain tension.

Grip the saw chain in the middle of the saw bar with your thumb and forefinger and pull the saw chain away from the saw bar. The distance that is created between the saw chain and the mating surface on the saw bar should be 3-4 mm.

### Replace saw chain

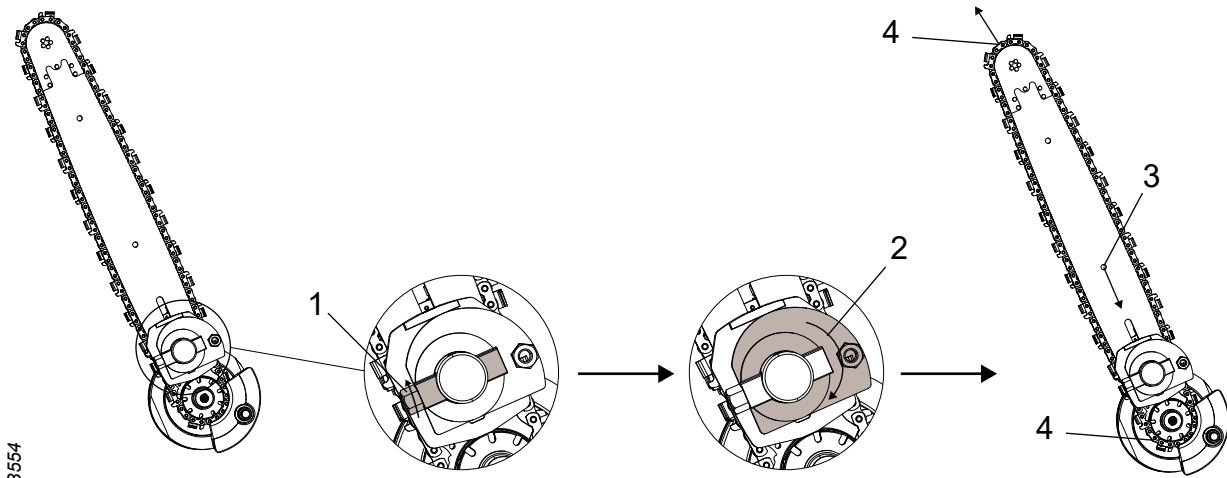

1. Loosen the preload on the saw bar by turning the locking shaft anti-clockwise. The locking shaft does not need to be rotated further than the point where the preload is released.
2. Release the saw chain tension by turning the eccentric clockwise.
3. Push in the saw bar.
4. Disengage the saw chain from saw bar's nose sprocket and the saw chain sprocket.
5. Install a new saw chain.
6. Tension the saw chain according to "Tension saw chain".

Replace saw bar

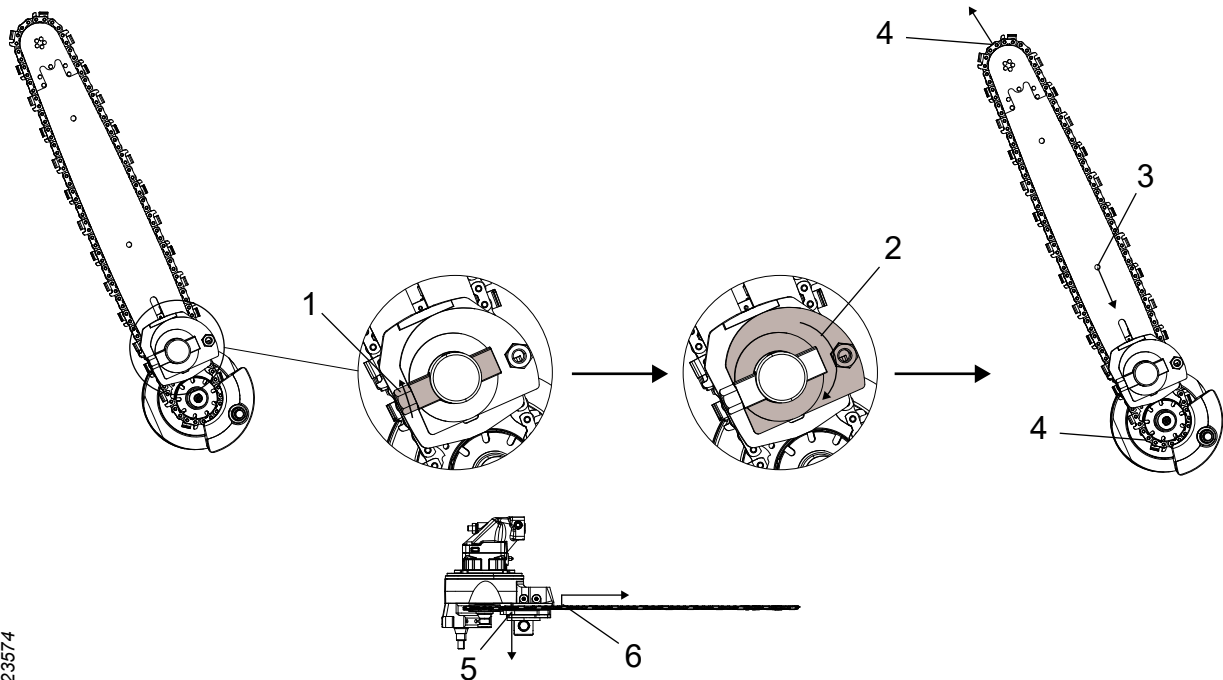

2223574

1. Loosen the preload on the saw bar by turning the locking shaft anti-clockwise. The locking shaft must be rotated so that its flat surface is facing the saw bar.
2. Release the saw chain tension by turning the excentre clockwise.
3. Push in the saw bar.
4. Disengage the saw chain from saw bar's nose sprocket and the saw chain sprocket.
5. Pull down the thrust washer and the excentre towards the locking shaft in order to release the saw bar.
6. Lift the saw bar so that it is free from the guide pins in the pressure plate and pull out the saw bar.
7. Install a new saw bar, making sure that the pressure plate's guide pins are fitted into the corresponding holes in the saw bar.
8. Turn the locking shaft so that the saw bar is pressed sufficiently firmly into place to allow the saw chain to be installed.
9. Install the saw chain and then tension it according to "Tension saw chain".

### Note!

If the saw bar has open grooves for the guide pins, the preload only needs to be released so that the thrust washer is no longer clamping the saw bar.

## Hydraulic system



### Warning!

The head's hydraulic system is fitted with accumulators. Pressure may remain in the system for some time after the pressure supply has been interrupted.



### Warning!

Risk of burns! Allow the head and hydraulic oil to cool before performing inspections and maintenance on the head.



### Caution!

Avoid skin contact with the head's liquids, as they can be harmful. Also avoid inhaling fumes.

### Important!

Risk of machine damage. Clean properly when working with the hydraulic system. Debris in the hydraulic system can cause extensive damage.

Park the head in accordance with "Parking in the tilted down position", unless otherwise indicated.

### Replacing the hydraulic hose



#### **Warning!**

When replacing the hydraulic hose, the new hose must have the same or a higher pressure class.

Hydraulic hoses that are designed to withstand pressures of more than 150 bar must not be installed with reusable hydraulic couplings. Hydraulic couplings that require special processing, such as crimping, are not considered to be reusable hydraulic couplings.

When a hydraulic hose is worn or has failed, it must be replaced according to:

#### **Hydraulic hose with ORFS couplings**

1. Start the vacuum pump, if the carrier is fitted with one.
2. Position a collection receptacle under the hydraulic hose to collect hydraulic oil spillage.
3. Clean around the hydraulic couplings.
4. Carefully loosen the hydraulic hose that is to be replaced.
5. Make sure that any pressure disappears and unscrew the hydraulic hose at both ends.
6. Remove the protective plugs from the new hydraulic hose.
7. Lubricate O-rings and seals with oil before assembly.
8. Lubricate the hydraulic hose nut at the rear edge (3), in order to reduce the risk of co-rotation of the hydraulic hose when tightening.

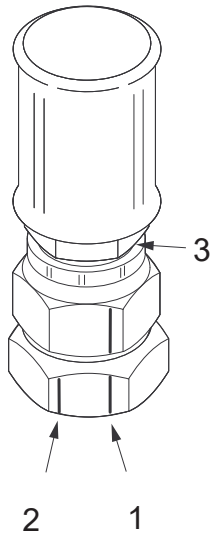

902697

9. Check that the hydraulic hose is protected and that the radius of any bends is as large as possible.
10. Tighten by hand and with a wrench until there is metal contact.
11. Then mark (with a marker pen) the starting point (1) for tightening on the adapter and hydraulic hose nut. Also mark the stopping point (2) on the adapter, 30° or half a wrench flat from the start (1).
12. Tighten the hydraulic hose so that the starting point mark (1) on the hydraulic hose nut is aligned with the stopping point mark (2) on the adapter. Make sure that the hydraulic hose is not twisted. Counterhold the hydraulic hose to protect the O-ring.
13. Wipe away the hydraulic oil spillage.

### Hydraulic hose with BSP couplings

1. Start the vacuum pump, if the carrier is fitted with one.
2. Position a collection receptacle under the hydraulic hose to collect hydraulic oil spillage.
3. Clean around the hydraulic couplings.
4. Carefully loosen the hydraulic hose that is to be replaced.
5. Make sure that any pressure disappears and unscrew the hydraulic hose at both ends.
6. Remove the protective plugs from the new hydraulic hose.
7. Lubricate the hydraulic hose nut at the rear edge, in order to reduce the risk of co-rotation of the hydraulic hose when tightening.
8. Check that the hydraulic hose is protected and that the radius of any bends is as large as possible.
9. Tighten by hand and with a wrench until there is metal contact.
10. Tighten the hydraulic hose to a tightening torque according to the table below. Make sure that the hydraulic hose is not twisted.
11. Wipe away the hydraulic oil spillage.

<b>Thread</b>	<b>Tightening torque [Nm]</b>
G 1/8	20
G 1/4	25
G 3/8	40
G 1/2	60
G 5/8	70
G 3/4	115
G 1	140
G 1 1/4	200
G 1 1/2	270
G 2	350

**Hydraulic hose with banjo coupling**

1. Start the vacuum pump, if the carrier is fitted with one.
2. Position a collection receptacle under the hydraulic hose to collect hydraulic oil spillage.
3. Clean around the hydraulic couplings.
4. Carefully loosen the hydraulic hose that is to be replaced.
5. Make sure that any pressure disappears and unscrew the hydraulic hose at both ends.
6. Remove the protective plugs from the new hydraulic hose.
7. Check that the hydraulic hose is protected and that the radius of any bends is as large as possible.
8. Replace the sealing element.
9. Tighten by hand and with a wrench until there is metal contact.
10. Tighten the hydraulic hose to a tightening torque according to the table below. Make sure that the hydraulic hose is not twisted.
11. Wipe away the hydraulic oil spillage.

Thread	Tightening torque [Nm]
G 1/8	10
G 1/4	20
G 3/8	45
G 1/2	70
G 3/4	130

**Hydraulic hose with JIC coupling**

1. Start the vacuum pump, if the carrier is fitted with one.
2. Position a collection receptacle under the hydraulic hose to collect hydraulic oil spillage.
3. Clean around the hydraulic couplings.
4. Carefully loosen the hydraulic hose that is to be replaced.
5. Make sure that any pressure disappears and unscrew the hydraulic hose at both ends.
6. Remove the protective plugs from the new hydraulic hose.
7. Lubricate the hydraulic hose nut at the rear edge (3), in order to reduce the risk of co-rotation of the hydraulic hose when tightening.
8. Check that the hydraulic hose is protected and that the radius of any bends is as large as possible.
9. Tighten by hand and with a wrench until there is metal contact.
10. Then mark (with a marker pen) the starting point (1) for tightening on the adapter and hydraulic hose nut. Also mark the stopping point (2) on the adapter, as shown in the table below.
11. Tighten the hydraulic hose so that the starting point mark (1) on the hydraulic hose nut is aligned with the stopping point mark (2) on the adapter. Make sure that the hydraulic hose is not twisted. Counterhold the hydraulic hose to protect the coupling.
12. Wipe away the hydraulic oil spillage.

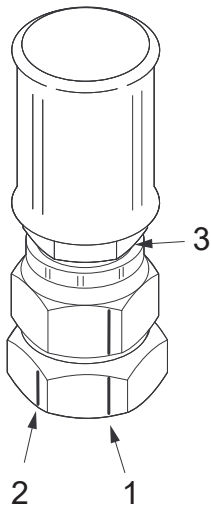

902788



Thread	Wrench flat	Degrees from the start
7/16"-20 UNF	2	120°
1/2"-20 UNF	2	120°
9/16"-18 UNF	2	120°
3/4"-16 UNF	2	120°
7/8"-14 UNF	1.5	90°
1 1/16"-12 UN	1	60°
1 5/16"-12 UN	1	60°
1 5/8"-12 UN	1	60°
1 7/8"-12 UN	1	60°
2 1/2"	1	60°

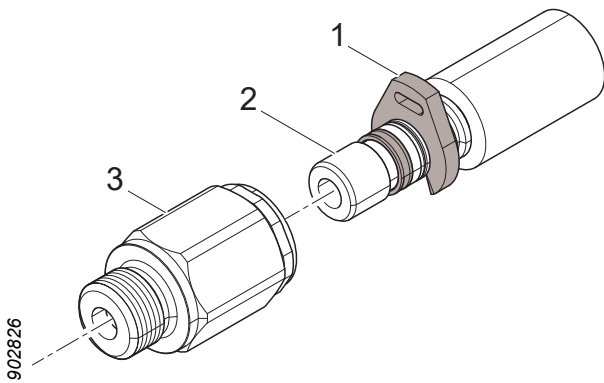

### Hydraulic hose with WEO coupling

1. Start the vacuum pump, if the carrier is fitted with one.
2. Position a collection receptacle under the hydraulic hose to collect hydraulic oil spillage.
3. Clean around the hydraulic couplings.
4. Use a screwdriver to remove the mounting stop (1) on the defective hydraulic hose.
5. Press the nipple (2) all the way into the hydraulic coupling (3) and then pull out the hydraulic hose.
6. Remove the protective plugs from the new hydraulic hose.
7. Check that the hydraulic hose is protected and that the radius of any bends is as large as possible.
8. Install the new hydraulic hose by pressing in the nipple (2) in the hydraulic coupling (3).
9. Wipe away the hydraulic oil spillage.

### Inspection and replacement of accumulators



**Warning!** Inspection of accumulators may only be carried out by technicians possessing the requisite knowledge.

To replace accumulator:

1. Clean around the hydraulic hose coupling and the accumulator.
2. Loosen the hydraulic hose to the accumulator according to "Replacing the hydraulic hose".
3. Unscrew the defective accumulator.
4. Screw the new accumulator into place.
5. Screw back the hydraulic hose according to "Replacing the hydraulic hose".

## Pressure check



### **Danger!**

Inspecting and adjusting pressure settings requires a person to remain within the reach of the head when the head is pressurised.

For this reason, this work may only be carried out by people who are very familiar with the function and design of the head.

The person in the carrier's cab must be very familiar with the operation of both the carrier and the head.



### **Warning!**

When connecting and disconnecting the pressure gauge, the head's hydraulic system must be depressurised.



### **Warning!**

The head's hydraulic system is fitted with accumulators. Pressure may remain in the system for some time after the pressure supply has been interrupted.

## Inspection and adjustment of the pressure setting

The settings apply at a hydraulic oil temperature of 40°C, a return pressure of 0 bar and a drainage pressure of 0 bar.

1. Warm up the hydraulic system to the specified temperature.
2. Run out the crane as far as possible in the carrier's most stable direction. Park the head in accordance with "Parking in the tilted down position".
3. Dismantle the guards required to access the measurement point that is to be used.
4. Connect a pressure gauge to the measurement point associated with the function to be checked.
5. The person reading off the pressure gauge must be located outside the reach of the carrier and the head.
6. Start the carrier. Lift the head off the ground.
7. Pressurise the head to a pressure at least 20 bar higher than the pressure that is to be set. Checking of certain functions requires a special procedure, see "Special Instructions".

8. Read off the set pressure on the pressure gauge and adjust if necessary.
9. Depressurise the hydraulic system and dismantle the pressure gauge.

## Pressure settings

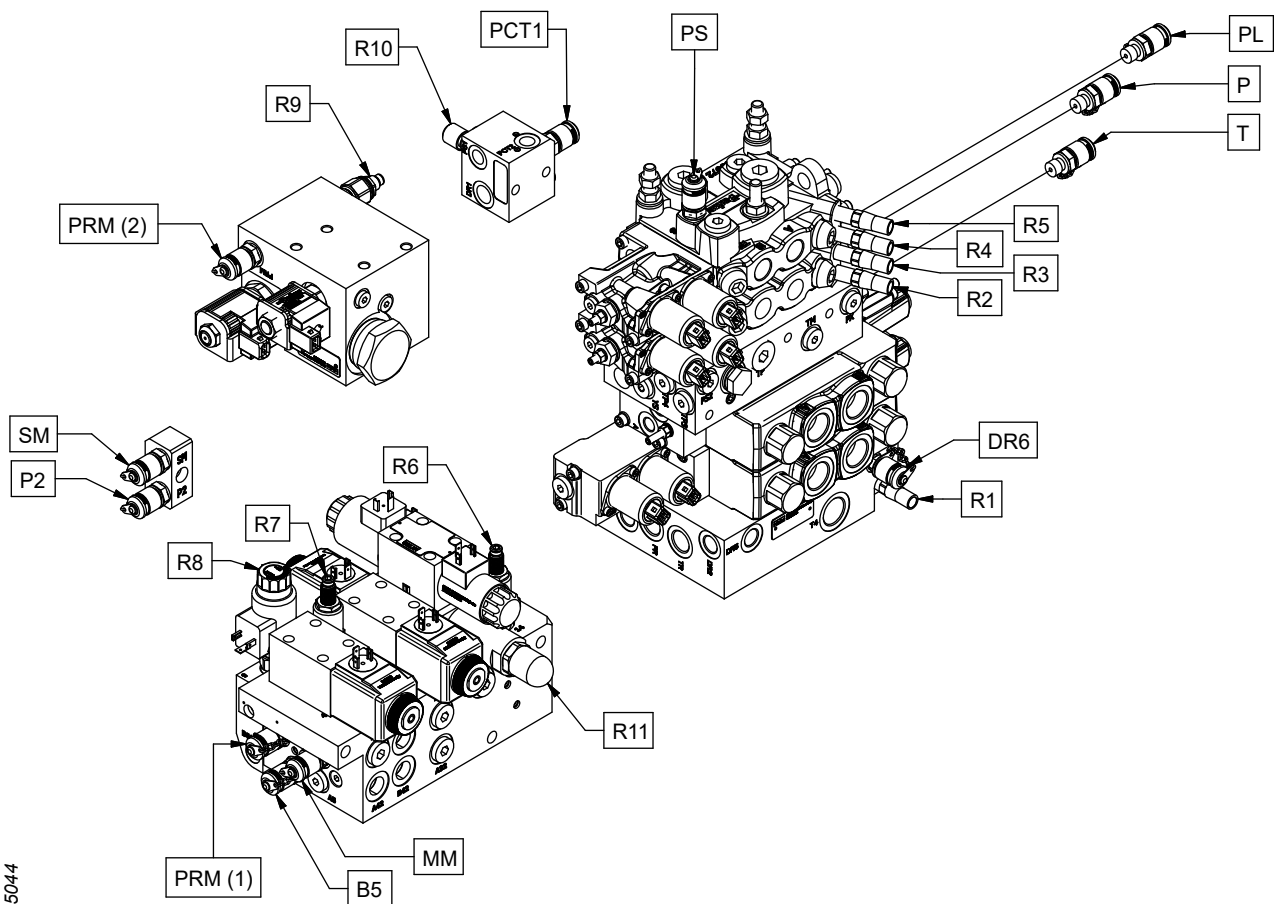

2315044

Function	Measurement point	Valve	Setting [bar]		Instruction
			Nominal	Max.	
Main pressure	P			320	Setting the main pressure.
Return pressure	T				Setting the main pressure.
Drainage pressure	DR6				Setting the main pressure.
Servo pressure	PS		35±2		Checking servo pressure.
Auxiliary function pressure (Felling link "tilt" up/down) (Colour marking) (Hydraulic upper delimiting knife) (Rotator)	P2	R1	180-5	180	
Lower delimiting knife close	PL	R2	140-5	140	Checking the function connected to "PL".
Lower delimiting knife open	PL	R3	70±5	75	Checking the function connected to "PL".
Right/left delimiting knife close	PL	R4	160-5	160	Checking the function connected to "PL".
Right/left delimiting knife open	PL	R5	70±5	75	Checking the function connected to "PL".
Bar feed (main saw)	SM	R6	30	35	Setting the bar feed pressure.
Feed roller arms	PRM (1)	R7	115±5	160	Adjusting the feed roller arm pressure.
Measuring wheel out	B5	R8	80±2	85	Checking measuring wheel pressure.
Bar feed (top saw)	PRM (2)	R9	90	120	Setting the bar feed pressure.
Saw chain tensioning (top saw)	PCT1	R10	15±3	20	Checking chain tensioning pressure for the top saw
Rotator	MM	R11	100±5	105	
Return pressure (top saw motor)	SRM				Checking return pressure, top saw motor

### Special Instructions

Checking and adjustment of certain pressure settings requires a special procedure according to the instructions below.

### **Setting the main pressure**

Checking and adjustment of the main, return and drainage pressure must be carried out by technicians possessing the requisite knowledge when servicing the head.

### **Checking servo pressure**

The plug in port "PS" is replaced by a measurement outlet.

### **Checking the function connected to "PL"**

The function that is to be checked must be activated in order to read off the pressure. The function must be activated throughout the period when the check is being performed. Take care to activate only one function at a time.

### **Setting the bar feed pressure**

The bar feed pressure must be adjusted according to the prevailing conditions (weather, tree species, etc.) to ensure optimum performance. The nominal setting is the recommended default setting.

### **Adjusting the feed roller arm pressure**

The feed roller arm pressure must be set as low as possible without the feed rollers slipping while feeding. The nominal setting is the recommended setting for steel rollers.

### **Checking measuring wheel pressure**

The "Measurement wheel out" pressure is set electrically via the control system.

### **Checking chain tensioning pressure for the top saw**

The pressure is only adjusted if the read value deviates from the nominal setting. The adjustment is made by fitting shims in the valve cap.

### **Checking return pressure, top saw motor**

This measurement point is for diagnostic/troubleshooting purposes only.

## **Extra equipment**

During inspection and maintenance of additional equipment. Park the head in accordance with "Parking in the tilted up position", unless otherwise indicated.

### Colour marking equipment

#### Topping up with marking dye

Check the marking dye levels and top up if necessary.

- 1. Tank filler cap
- 2. Tool for tank filler cap

- A Open
- B Close

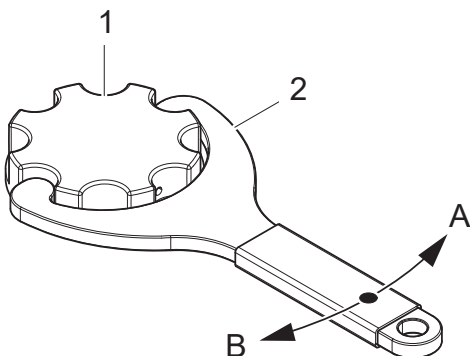

952846

#### Important!

Do not use salt-based marking dye. Salt increases the risk of corrosion occurring in the colour marking system.

#### Cleaning non-return valve in tank filler cap

- 1. Remove the non-return valve (1) in the tank filler cap and clean the non-return valve (1) with a cleaning liquid according to the dye manufacturer's recommendations.
- 2. Clean the duct (2) in the tank filler cap with a cleaning liquid according to the dye manufacturer's recommendations.
- 3. Reinstall the non-return valve (1).

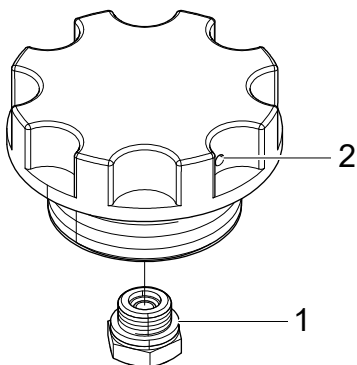

903060

#### Inspecting the colour marking pump

Remove the guard for the colour marking pump and check for leaks at leak holes L1 (1) and L2 (2).

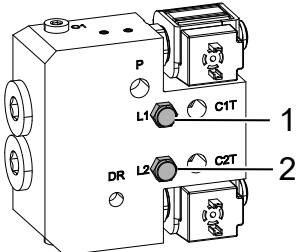

903064

### **Important!**

In the event of leakage of hydraulic oil or marking dye, troubleshooting and repair of the colour marking pump must be carried out by technicians possessing the requisite knowledge.

### **Cleaning the colour marking system**

1. Check the strainers under the tank cap in the dye tanks and clean as necessary.
2. Clean the non-return valves in the tank filler caps according to "Cleaning non-return valve in tank filler cap".
3. Add the cleaning fluid recommended by the dye manufacturer in the colour tanks.
4. Activate the colour marking functions until all cleaning fluid has passed through the system.
5. Top up with new marking dye.

### **In the event of long breaks (several weeks)**

If colour marking is not going to be used regularly:

1. Clean the colour marking system according to "Cleaning the colour marking system" up to and including point "4".
2. Pour in a few decilitres of hydraulic oil and activate the colour marking functions 5-10 times so that the colour marking system is filled with hydraulic oil.
3. Before the next use, activate the colour marking functions until all hydraulic oil has passed through the system.
4. Top up with new marking dye.

### **Find End**

Make sure there is no debris in the way of the laser sensor's scanning area. Clean if necessary.

### **Important!**

Replacement and troubleshooting of the laser sensor must be carried out by technicians possessing the requisite knowledge.



### Repair welding

Repair welding may only be carried out by technicians possessing the requisite knowledge according to the welding instructions supplied by Log Max AB .

#### **Important!**

During welding work on the head, there is a considerable risk of electric components being destroyed.



# Maintenance schedule

## Lubrication schedule, 8 h

All lubrication points on the head are accessible when the head is parked according to "Parking in the tilted up position".

### Note!

To facilitate lubrication of the delimiting knives, it may be beneficial not to open the delimiting knives fully when parking the head. This is so that the position of the grease nipples can be adjusted slightly by pulling the knives.

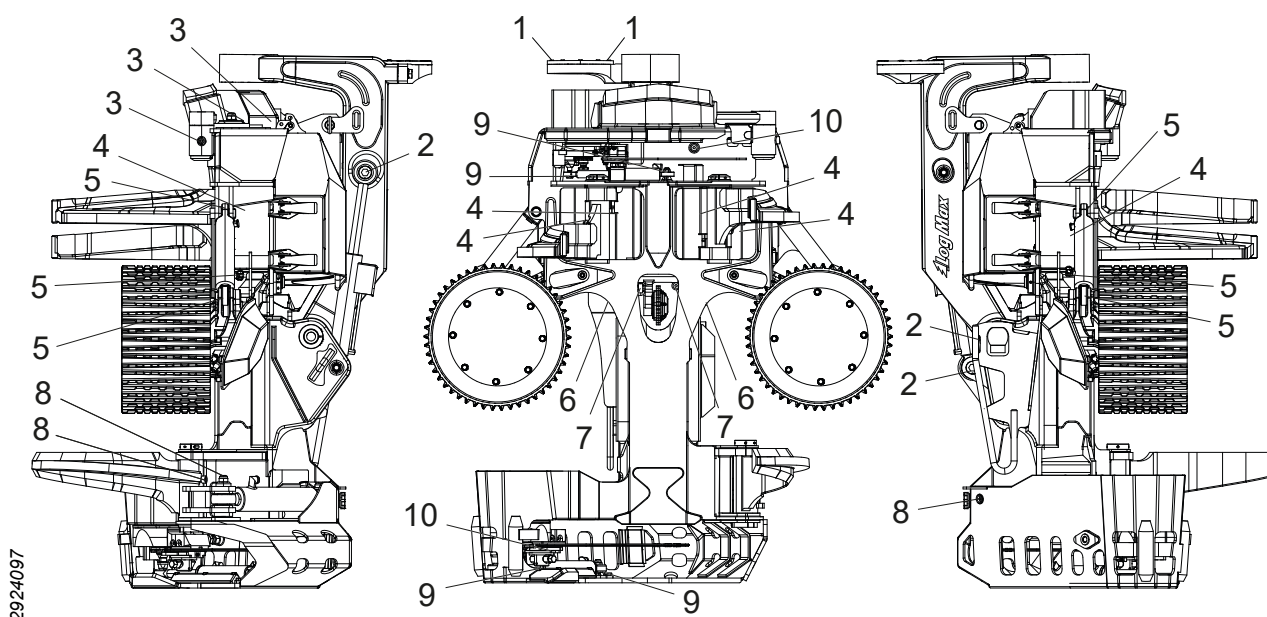

Pos.	Lubrication point	Comment	Number
1	Hose holder		2
2	Felling link with cylinder		3
3	Upper delimiting knife		3
4	Right and left delimiting knives with cylinders		6
5	Feed roller arms with cylinders		6
6	Measuring wheel arm		2
7	Measuring wheel cylinder		2
8	Lower delimiting knife with cylinder		3
9	Bar feed cylinder		4
10	Saw unit	Bearing	2

Maintenance schedule, 8 h

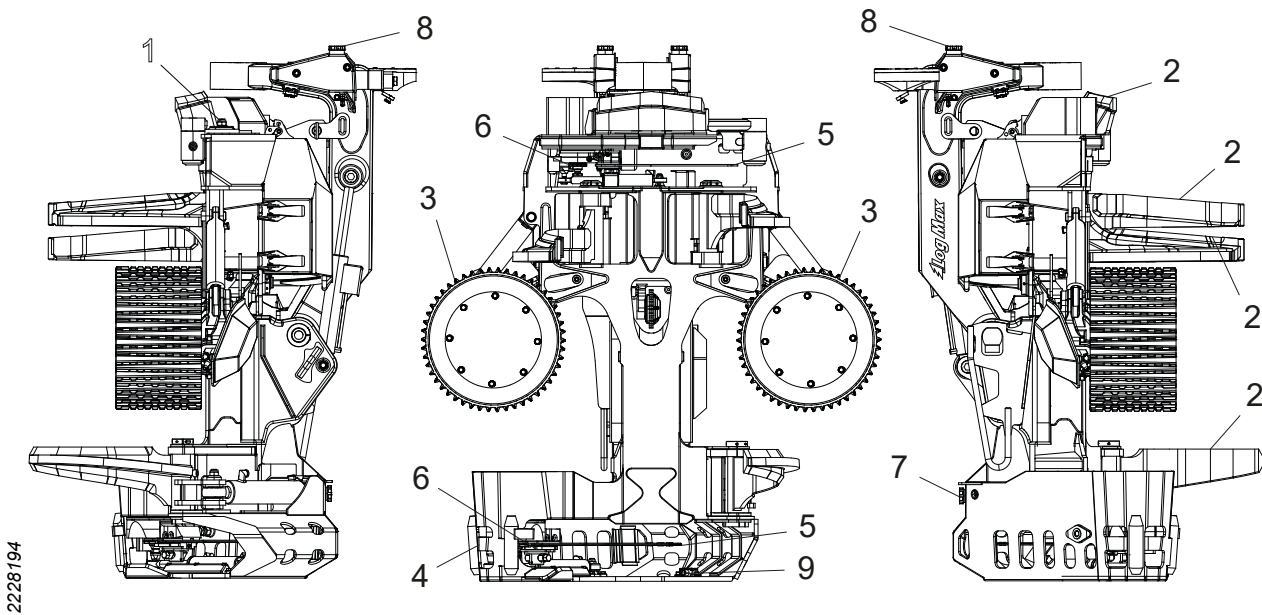

2228194

Pos.	Maintenance points	Action	Page
	Head	Rough cleaning	52
	Saw chain lubrication	Function test	68
	Hoses and cables	Check, replace if necessary	76
	Tension belts	Check, tension/replace if necessary	
1	Upper delimiting knife	Checking and adjusting the upper delimiting knife's screw and nut in the groove	61
2	Delimiting knives (all)	Check edges and sharpen if necessary	57
3	Feed roller	Inspecting feed rollers	62
4	Chain shot guard	Check, replace if necessary	67
5	Saw bar and saw chain	Check, replace if necessary*	68, 68
6	Saw chain sprocket and saw chain catcher	Check, replace if necessary	69
7	Saw chain oil	Top up saw chain oil*	67
8	Colour marking dye	Check level and top up if necessary*	87
9	Find End	Cleaning in front of laser*	88

\* May need to be performed more frequently than every 8 hours.

## Maintenance schedule, 50 h

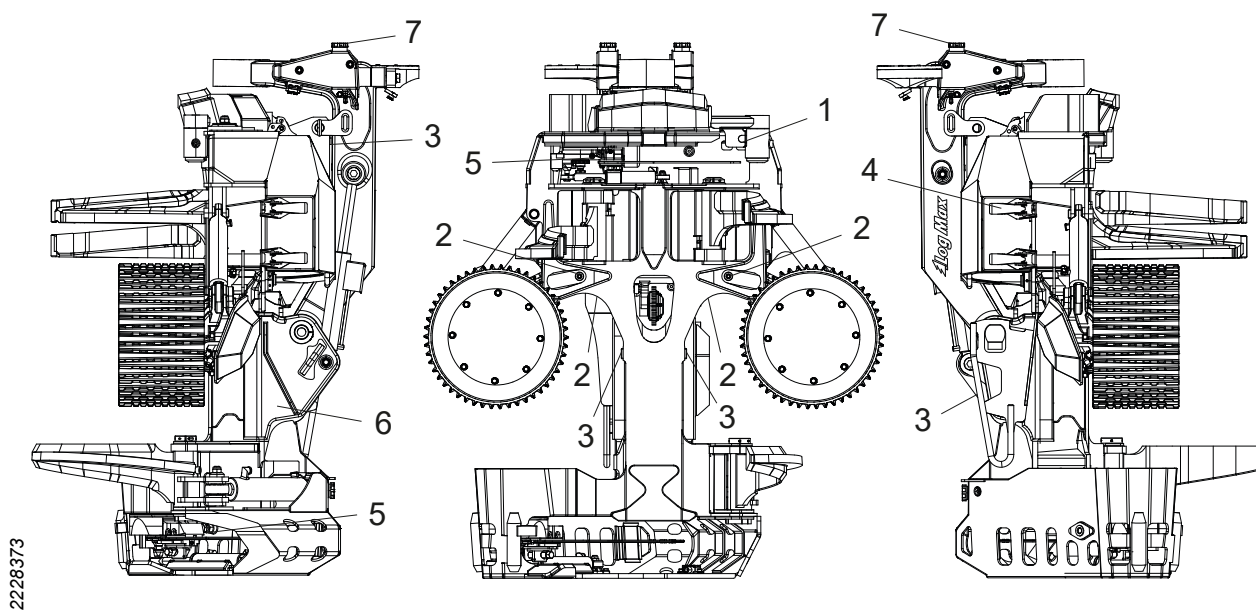

2228373

Pos.	Maintenance points	Action	Page
	Head	Make sure that the head does not have any cracks	53
	Cotter pins	Check, replace if necessary	
	Protection	Checking screws, tightening	104
	Electrical wiring	Inspecting electrical wiring	53
	Diameter measurement unit	Inspection	63
1	Upper delimiting knife	Upper delimiting knife's spring and its preload	59
2	Roller arms, delimiting knives, felling link	Checking locking screws for shafts	55
3	Roller arms, felling link	Check stop buffers, replace if necessary	53
4	Protective cover	Inspecting and adjusting the protective cover and over-centre latches	54
5	Saw unit	Clean behind the bar holder	72
6	Colour marking equipment	Inspecting the colour marking pump	87
7	Colour marking equipment	Cleaning non-return valves in tank filler caps	87

## Maintenance schedule, 250 h

### Important!

After the first 250 operating hours, all maintenance measures must be performed.

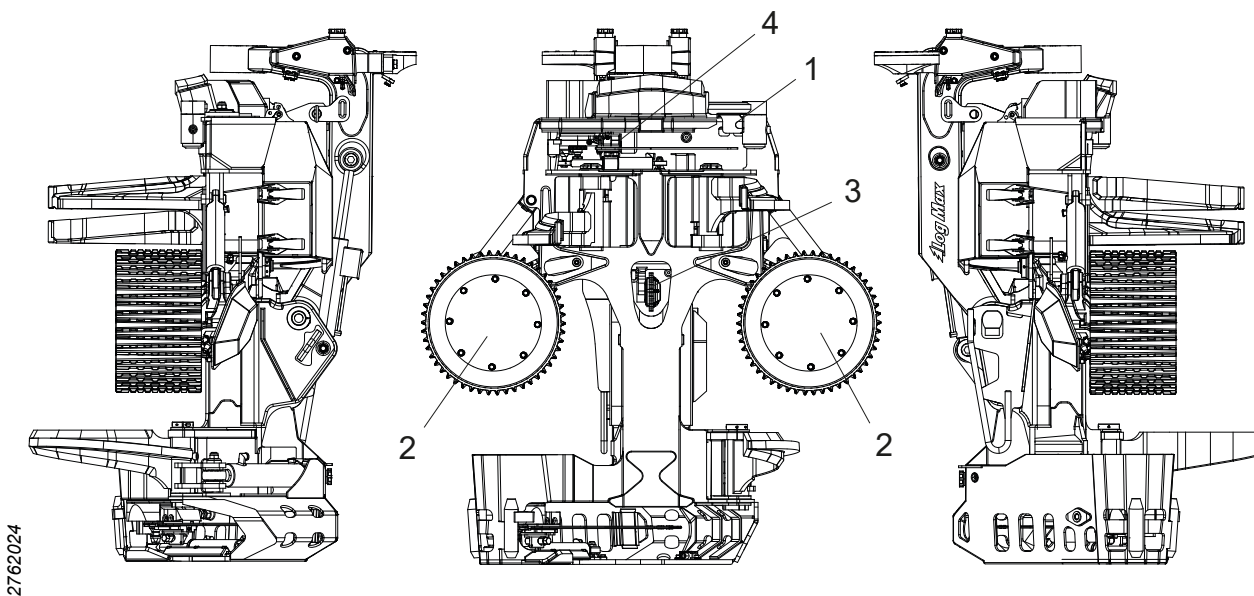

Pos.	Maintenance points	Action	Page
	Hydraulic system	Pressure check	83
1	Upper delimiting knife	Inspection and adjustment of sensors	60
2	Feed roller	Tightening nuts	62
3	Length measurement unit	Inspecting the length measurement unit	64
4	Saw unit	Checking the stop screw	71

### Maintenance schedule, 1,000 h

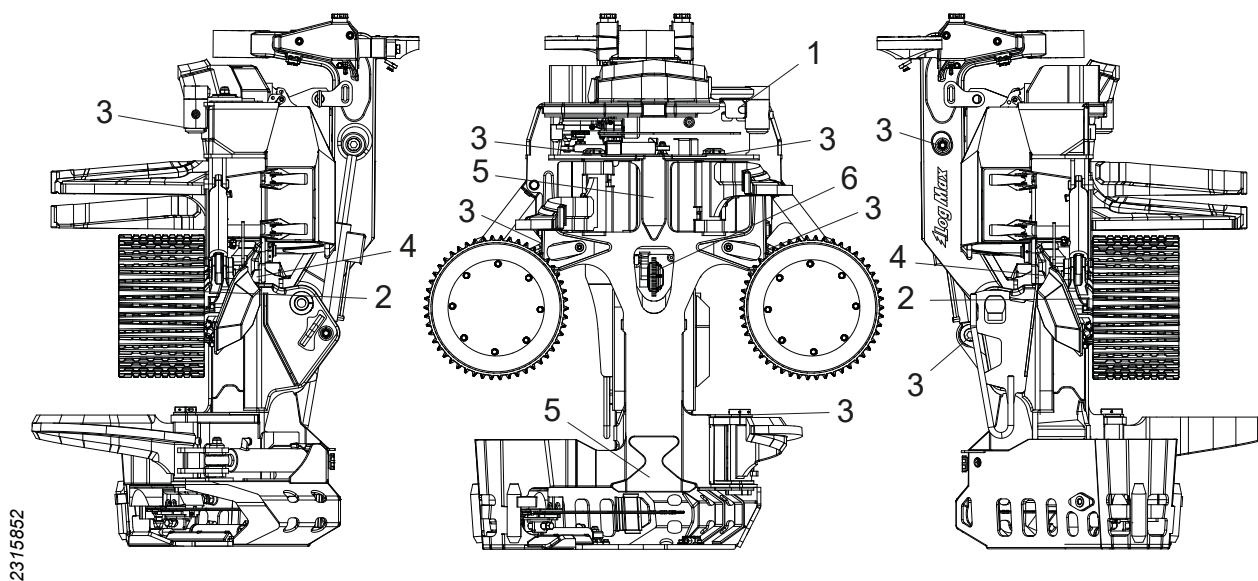

Pos.	Maintenance points	Action	Page
1	Upper delimiting knife	Basic setting of sensors	60
2	Feed roller motors	Tightening, screws	63
3	Roller arms, delimiting knives, felling link	Inspecting axial play	56
4	Expander	Inspecting axial play	55
5	Wear plates	Inspecting wear plates	54
6	Length measurement wheel	Lubricating bearings	66





## Service information

Servicing of the head must be carried out by technicians possessing the requisite knowledge according to the enclosed service manual.

Electrical and hydraulic diagrams can be obtained upon request from Log Max AB.



## Troubleshooting

### Fault

The upper delimiting knife tends to be lifted from the stem or cuts into the stem, despite correct sharpening.

No saw chain oil is reaching the saw bar.

Problems with diameter measurement.

Problems with length measurement.

### Probable fault - Action

- The spring and its preload need to be checked and adjusted if necessary, see "Upper delimiting knife's spring and its preload".
- Saw chain oil has run out. Top up with saw chain oil.
- Clogged strainers. Clean the strainers in the system.
- Clogged ducts. Clean the ducts in the bar mount and the saw bar.
- Incorrect settings in the control system.
- Clogged vent hose or its filter.
- Clogged or defective lubricating pump.
- Incorrectly set hydraulic pressure.
- Defective accumulators, see "Inspection and replacement of accumulators".
- Worn or oval feed rollers.
- Damaged diameter sensor.
- Cable breakage to the diameter sensor.
- Incorrectly set hydraulic pressure.
- Defective accumulator for the measurement wheel cylinder; see "Inspection and replacement of accumulators".
- Incorrect setting of upper delimiting knife sensor.
- Incorrect calibration of the length measurement unit.
- Damaged sensor.
- Cable breakage to the length measurement sensor.
- Play in the length measurement unit.
- Movement of the measurement wheel arm is blocked by debris.



## Technical data

### Dimensions and weight

#### Dimensions and basic weight.

Basic weight*	2270 kg
Min. width	1397 mm
Max. width	1956 mm
Height to upper delimiting knife	2086 mm
Height to felling link	2206 mm
Max. tree diameter, DBH	500 mm
Max. cutting diameter	800 mm
Max. cutting diameter, top saw	490 mm
Min. opening between the feed rollers, V-steel	7 mm
Max. opening between the feed rollers, V-steel	732 mm
Max. opening between delimiting knives	740 mm

\* Basic weight refers to an operable head with Parker V12 feed roller motors, V-steel Hard Grip feed roller, saw 611 (main saw), saw 318 (top saw) and filled with oils.

#### Weight of extra equipment

Feed roller, V-steel Soft Grip	+6 kg
Feed roller, Eucalyptus	+14 kg
Feed wheel motor MS11 1259 ccm	+72 kg
Colour marking, two colours (including 6 l dye)	+39 kg
Built-in rotator control	+5 kg
Find End	+2 kg
Stump treatment	+1 kg

### Noise level

LWA = 110 dB (A)\*

\* The noise level is measured according to EN ISO 3744:2009 with a margin of error of  $\pm 2$  dB(A) according to EA-4/16:2003. The noise level is measured when the head's saw motor is activated without any load at the maximum permitted speed.

### Temperature

Do not use the head if the outside temperature is below  $-35^{\circ}\text{C}$ .

## Hydraulics

### Hydraulic oil requirements

Hydraulic oil according to DIN 51524			HL or HLP
Purity according to ISO 4406			15/13/11
Viscosity	Normal work	min.	15 mm <sup>2</sup> /s
		nominal	30 mm <sup>2</sup> /s
	Start-up	max.	380 mm <sup>2</sup> /s
Hydraulic oil temperature	Normal work	min.	20°C
		max.	70°C

The head has been test-operated with Q8 Hummel 46 before delivery.

### General recommendations

Max. engine power in carrier	188 kW
Max. hydraulic power, from hydraulic pump	154 kW
Max. hydraulic pressure, at hydraulic pump	320 bar
Max. hydraulic oil flow	350 l/min

### Minimum hydraulic system requirements

Min. engine power in carrier	103 kW
Min. hydraulic power, from hydraulic pump	84 kW
Min. hydraulic pressure, at hydraulic pump	250 bar
Lowest standby pressure	35 bar
Min. hydraulic oil flow	250 l/min

### Saw chain speed

The max. saw chain speed is:

- 30 m/s for a saw chain with 3/4" pitch.
- 40 m/s for a saw chain with 0.404" pitch.

If the saw chain manufacturer prescribes a lower saw chain speed than that specified above, the saw chain manufacturer's regulations must be followed.

If components are replaced which can alter the saw unit's saw chain speed, the speed of the saw motor must be checked so that the prescribed saw chain speed is not exceeded.

## Lubricant

### Important!

Never mix different types of lubricant unless it is expressly stated that this may take place. Each lubricant has its own additive which gives it specific properties. When different lubricants are mixed, these properties can be altered, resulting in a breakdown.

### Requirements regarding saw chain oil

To achieve good lubrication properties in saw unit and pump, a saw chain oil is required that works in varying climates while retaining function. The saw chain oil must be non-viscous, have good adhesion and satisfactory lubrication effect on saw chain and saw bar, at the same time as strainers and lubricating ducts do not become clogged.

Using a saw chain oil with too high a viscosity number leads to the saw chain oil becoming viscous at low temperatures, which results in a deterioration in the efficiency of the lubricating pump. These problems result in wear and tear on the lubricating pump and saw unit, which in turn can lead to recurring malfunctions. This may continue even after changing to a less viscous saw chain oil.

Use a bio-oil with an ISO VG number of between 32 and 68.

The viscosity index must be higher than 180 and adapted to the prevailing climate.

The lubricating pump has been test-operated with Q8 T65 75W-90 before delivery.

### Lubricating grease

The lubricating grease used must have good lubricating properties and good adhesion in the event of:

- low rpm.
- high load.
- oscillating movements.
- powerful vibrations.
- shock loads and frequent starts.
- the temperature that the bearing can reach during operation.

The lubricating grease must not contain sulphides such as molybdenum disulphide or zinc sulphide. The lubricating grease must also not contain graphite as an additive.

For optimum function and service life, it is also recommended that the grease that is used:

- has rust-proofing properties.
- has good water-repellent capability.
- is biodegradable.

The head is lubricated with Q8 Rembrandt EP2 before delivery.

### General tightening torques

The following general tightening torques apply unless otherwise stated.

<b>Tightening torque for oiled steel screw joints.</b>				
		<b>Class according to SS-ISO 898-1</b>		
<b>Thread</b>	<b>Pitch [mm]</b>	<b>8.8 [Nm]</b>	<b>10.9 [Nm]</b>	<b>12.9 [Nm]</b>
M3	0.50	1,2	1.7	2,1
M4	0.70	2,9	4	4,9
M5	0.80	5,7	8,1	9,7
M6	1.00	9,8	14	17
M8	1.25	24	33	40
M10	1.50	47	65	79
M12	1.75	81	114	136
M14	2.00	128	181	217
M16	2.00	197	277	333
M18	2.50	275	386	463
M20	2.50	385	541	649
M22	2.50	518	728	874
M24	3.00	665	935	1120
M27	3.00	961	1350	1620
M30	3.50	1310	1840	2210
M33	3.50	1770	2480	2980
M36	4.00	2280	3210	3850



## General tightening torques with Nord-Lock washers

Tightening torques for oiled steel screw joints with Nord-Lock washers.				
		Class according to SS-ISO 898-1		
Thread	Pitch [mm]	8.8 [Nm]	10.9 [Nm]	12.9 [Nm]
M3	0.50	1.7	2	2,2
M4	0.70	3,8	4,5	5,1
M5	0.80	7,5	8,9	10
M6	1.00	13,1	15,5	17,4
M8	1.25	32	37	42
M10	1.50	62	73	82
M12	1.75	107	126	142
M14	2.00	170	201	226
M16	2.00	260	307	345
M18	2.50	364	430	483
M20	2.50	510	602	676
M22	2.50	696	821	921
M24	3.00	878	1036	1165
M27	3.00	1284	1514	1700
M30	3.50	1750	2064	2318
M33	3.50	2360	2783	3124
M36	4.00	3043	3589	4029

## General tightening torque for Expander

Tightening torque for Expander								
Thread	M12	M14	M16	M20	M24	M30	M36	M42
Nm	70	115	175	350	500	600	700	900



**Log Max**

**7000XT Top Saw**

User Manual  
in Original

371001-  
en

**Log Max**

**7000XT Top Saw**

User Manual  
in Original

371001-  
en

**Log Max**

**7000XT Top Saw**

User Manual  
in Original

371001-  
en

**Log Max**

**7000XT Top Saw**

User Manual  
in Original

371001-  
en

**Log Max**

**7000XT Top Saw**

User Manual  
in Original

371001-  
en

**Log Max**

**7000XT Top Saw**

User Manual  
in Original

371001-  
en

**Log Max**

**7000XT Top Saw**

User Manual  
in Original

371001-  
en